

# Critical Asset Monitoring

## Humidity Sensor



The IntelliSAW Humidity Sensor provides real-time, continuous monitoring of electrical power critical assets to identify the potential for flashover. The sensor's sintered cap, threaded body, water resistant M12 connector, and 4kV surge protection provides the level of packaging robustness required for reliable operation in harsh environments. The IntelliSAW Critical Asset Monitoring (CAM) platform units allows up to 8 humidity sensors to be bussed together for multiple location installations such as along a bus duct.

### Features

- Relative humidity and ambient temperature
- Designed for electrical critical asset environments
- Multi-drop bus for up to 8 series connected sensors

### Specifications

#### Humidity Measurements

Range	0 to 100% Relative Humidity (%RH)
Resolution	± 0.1 %RH
Accuracy	
Standard Range (20 to 80%RH)	± 4.5 %RH
Full Range	± 7.5 %RH
Repeatability	± 0.2 %RH
Long-term Drift	< 0.5 %RH/yr

#### Ambient Temperature Measurements

Range	-25°C to +120°C
Resolution	± 0.1°C
Accuracy	± 2.5°C
Repeatability	± 0.2°C
Long-term Drift	< 0.1°C/yr

#### Physical

Material	304 Stainless steel
Sintered Cap Material	Nickel plated bronze
Weight	0.1 kg (3.5 oz)
Ingress Protection (IEC 60529)	Connector side (IP 67), Cap side (IP 50)
Dielectric Strength	4 kV
Dimensions	28 W x 28 H x 80 mm D
Operating Conditions	Connector side: -20oC to +70oC

#### Mounting & Connectors

Body Thread	M22 x 1.5 thread (nut included)
Body	24 mm hex body
Connector	M12, 4-pole socket

## Cables

IntelliSAW cables use UL style 2464, (80C, 300V) communication cable assembled with the required connectors to interface between a humidity sensor and an IntelliSAW CAM-4 or Reader.

## Bussed sensors

IntelliSAW monitoring units are capable of reading up to 8 bussed humidity sensors through sensor addressing. The following is an example of 3 humidity sensors being bussed.

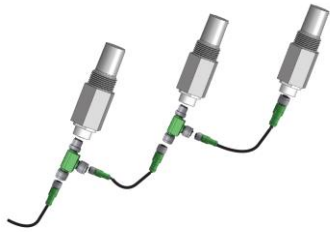

## Mounting

**Panel Mount:** The sensor body can be inserted into a 22.5mm punch out and fastened with a M22 x 1.5 thin hex nut.

**Bracket Mount:** The sensor can be connected to a bracket for alternative mounting methods. Bracket size: 44.5 W x 38 H x 38mm L



## Safety

IntelliSAW systems are installed in close proximity to medium and high voltage electric power equipment. Qualified personnel need to observe industry standard safety practices that will protect the systems and operators from harm due to induced voltages. Proper antenna installation and system safety grounding is crucial to operator safety and system reliability.



## Mechanical

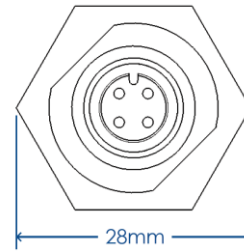
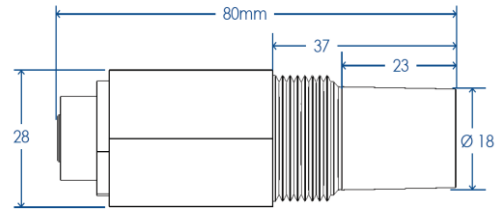

## Model numbers

Not all model combinations are stocked. Please contact sales before ordering.

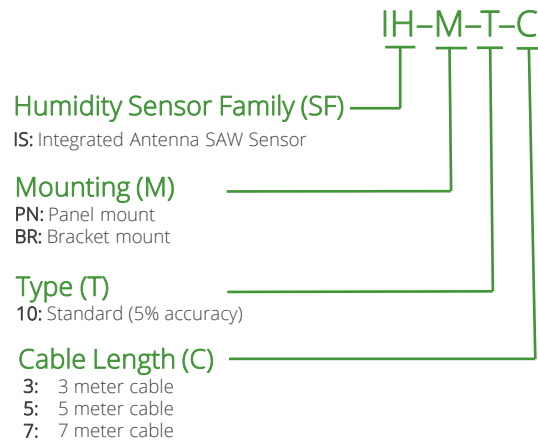

## Homologation

System integrators and installers are responsible for adhering to all regional regulations concerning the import, installation and operation of IntelliSAW Critical Asset Monitoring systems.