



Istrumentazioni Sistemi Automatici S.r.l.

VIA PRATI BASSI 22 - 21020 TAINO (VA) - ITALY

OFFICES TEL. +39.0331.956081 - FAX +39.0331.957091

E-MAIL isa@isatest.com

WEB www.isatest.com

DATE: 02/11/2016 DOC.SIE40171 REV. 1.8

TFS-2100E Travelling Wave Fault Locator System Description and Specification

EXECUTIVE SUMMARY	7
ABBREVIATIONS	8
1 OVERVIEW.....	9
2. FAULT LOCATION PRINCIPLE.....	14
2.1 TYPE D (DOUBLE ENDED) METHOD	14
2.2 TYPE A (SINGLE ENDED) METHOD	15
2.3 TYPE E METHOD	15
2.4 TYPE W (WIDE AREA) METHOD	16
2.5 APPLICATION OF DIFFERENT METHODS	19
3. MEASUREMENTS OF TRAVELLING WAVES	20
3.1 AC POWER LINE	20
3.1.1 <i>More than one line on the bars</i>	20
3.1.2 <i>One line on the bars</i>	21
3.2 HVDC TRANSMISSION LINE	23
4. SYSTEM DESCRIPTION AND PERFORMANCE... 24	24
4.1 TRAVELLING WAVE DATA ACQUISITION UNIT TDU-100E 25	25
4.2 MASTER STATION SOFTWARE TAS-2100E	25
4.3 TFS-2100E SYSTEM PERFORMANCES	26
4.3.1 <i>Performances in normal operation</i>	26
4.3.2 <i>The impact of harmonics variations</i>	27
4.3.3 <i>Critical operation condition</i>	27
4.3.4 <i>Fault location accuracy</i>	27
4.3.5 <i>Network configuration</i>	27
4.3.6 <i>Fault resistance sensitivity</i>	29
4.3.7 <i>System organization</i>	29
4.4 TFS-2100E FUNCTIONS AND FEATURES.....	31
5. COMMUNICATION	33
5.1 DIAL UP.....	33
5.2 POINT TO POINT CONNECTION	34
5.3 TCP/IP NETWORK.....	35
6. TDU-100E SPECIFICATIONS	37
6.1 FRONT PANEL.....	37
6.2 DEVICE CHARACTERISTICS	40
6.2.1 <i>A/D conversion</i>	40
6.2.2 <i>Location accuracy</i>	40
6.2.3 <i>Trigger</i>	40
6.2.4 <i>Length of transient recording</i>	41

6.2.5	<i>Data storage</i>	41
6.2.6	<i>Recording content</i>	41
6.2.7	<i>Self- diagnostics</i>	41
6.3	REAR PANEL	42
6.4	MODULES CHARACTERISTICS	42
6.4.1	<i>Analog Inputs modules</i>	42
6.4.2	<i>Binary inputs</i>	44
6.4.3	<i>Time synchronization</i>	45
6.4.4	<i>Communication ports</i>	48
6.4.5	<i>Power supply</i>	49
6.4.6	<i>Logic output DO module</i>	50
6.4.7	<i>Packing list</i>	50
6.5	EXAMPLES OF ANALOG CHANNELS CONFIGURATIONS.....	51
7	SYSTEM CONFIGURATION	54
7.1	BASIC CONFIGURATION; IP CONNECTION.....	54
7.2	BASIC CONFIGURATION; DIAL-UP CONNECTION.....	56
7.3	HARDWARE AND SOFTWARE REQUIREMENTS	56
7.4	TAS-2100E SOFTWARE SYSTEM ARCHITECTURE	57
8.	TAS-2100E FUNCTIONS DESCRIPTION	58
8.1	FUNCTIONS.....	58
8.2	SYSTEM MANAGEMENT	60
8.3	COMMUNICATION	61
8.4	GRAPHICS	62
8.5	ALARM	62
8.6	DATA MANAGEMENT	63
8.7	DATA ANALYSIS	63
8.8	FAULT LOCATION	64
8.9	GOOGLE MAP	64
8.10	PRINTING	65
8.11	INTERFACE WITH EXTERNAL SYSTEMS	65
8.12	OVERALL FEATURES.....	65
9	OPTIONAL TSG-10 IMPULSE GENERATOR.....	66
	APPLICABLE STANDARDS	68
A1	ELECTROMAGNETIC COMPATIBILITY	68
A2	SAFETY.....	70
A.3	OPERATING CONDITIONS.....	70
TDU-100E	SELECTION FORM.....	71
APPENDIX 1:	SUMMARY OF AVAILABLE MODULES .	74

Copyright © 2013 by ISA.

Disclaimer

Every effort has been made to make this material complete, accurate, and up-to-date. In addition, changes are periodically added to the information herein; these changes will be incorporated into new editions of the publication. ISA S.R.L reserves the right to make improvements and/or changes in the product(s) and/or the program(s) described in this document without notice, and shall not be responsible for any damages, including but not limited to consequential damages, caused by reliance on the material presented, including but not limited to typographical errors.

NOTE: in the following, Windows is a registered trademark of MICROSOFT.

EXECUTIVE SUMMARY

The following document is bulky, with many details about how and what. However, the key facts about TFS-2100E are as followings:

- The installation and set-up of the standard hardware is very simple: it requires about 20 wires and one day installation time at maximum.
- Once in service, in a matter of seconds the main unit can locate the faulty tower, allowing the repairing squad to be dispatched.
- The increasing number of units installation confirms the high reliability of the system and the success in locating faults.

ABBREVIATIONS

TDU	Traveling Wave Data Acquisition Unit
TAS	Traveling Wave Analysis Software
TFS	Traveling Wave Fault Locator System
EHV	Extreme High Voltage
CT	Current Transformer
VT	Voltage Transformer
CB	Circuit Breaker
CVT	Capacitor Voltage Transformer
HVDC	High Voltage Direct Current

1 OVERVIEW

Transmission lines are important parts for the electrical network, and need to be installed across long distance, causing transmission lines vulnerable to all kinds of faults. However, due to complicate weather and field conditions, it is sometimes difficult to patrol the lines, and thus it is vital to employ equipment that can locate the fault with the accuracy of one tower. It is also important to have a system capable of locating recurrent intermittent faults, like swaying trees, with high impedance faults (up to several hundreds of Ohm) or breaking of the conductor, which impair the reliability of the power line.

The traveling wave based fault locator was first proposed in 1950 and was made feasible for practical field applications in 1990s thanks to the advent of microelectronic-based ultra-high speed data acquisitions and time synchronizations using GPS receivers. ISA has accomplished this by introducing the Travelling Wave Fault Locator System TFS-2100. In the year of 1995, the first TFS-2100 systems were installed, and in 2000, the second generation was successfully developed.

While, in the past, travelling wave fault locators measured transient voltages using specially designed capacitor couplers attached to the high voltage bus, the modern system measures the transient signals of existing current transformer (CT) secondary. It makes the system installation very easy and cost effective.

By the end of 2012, more than 2000 TFS-2100 systems have been installed around the world. The system demonstrated high performance in its reliability and locating accuracy. TFS-2100E is the third generation; including the new hardware module TDU-100E (Traveling Wave Data Acquisition Unit) and the new software TAS-2100E and TAS WEB.

TDU-100E has been developed in order to exploit the power of the latest microelectronics components.

TAS-2100E is the evolution of the former TAS-2100: it comes from the improvements of TDU-100E, and from the long experience gained in many years of use.

- The Travelling Wave Fault Locator System TFS-2100E can accurately locate faults in transmission and distribution power lines.

- Fault distance measurement errors is less than 50 m independent of line length, and are free from the following factors which can affect fault location accuracy of traditional impedance measurement methods:
 - Fault resistance;
 - Voltage and current transformer (VT, CT) errors;
 - Insufficient accuracy of line parameters due to neglecting of line transposing, distributed capacitance, etc.;
 - Uncertainty of zero sequence impedance due to variance of soil resistivity along the line corridor;
 - Load flow.
- Unlike the impedance measurement method, which is limited to locating short-circuit faults in AC power lines, the travelling wave technique can be used to measure the distance to fault in all kinds of power lines, including:
 - AC transmission lines;
 - HVDC transmission lines;
 - Series compensated transmission lines;
 - Lines with T branches;
 - Lines with variable impedance;
 - Lines made of cable and overhead line (mixed lines);
 - Three phase double line transmission;
 - Measuring the fault distance of a single phase to ground fault in non-effectively earthed distribution system.

The following table summarizes the enhancements of TDU-100E with respect to TDU-100, which was the main component of TFS-2100.

Item	TDU-100E	TDU-100
Number of units	One: TDU-100E	Base: TDU-100. Options: GPS2000, DPS-100
Hosted modules	14	9
Analog inputs	Maximum 24 channels for 8 lines	Maximum 12 channels for 4 lines
Sampling frequency	Maximum 36 MHz (one conductor)	Maximum 12 MHz
Time duration of fault recording	Maximum 20ms	Maximum 20ms
Power frequency fault current measurement	Yes	No
Internal data storage (nonvolatile)	8GByte	2 MByte. Optional DPS-100 for 1 GByte.
Time synchronization	Internal GPS module with 100 ns accuracy; external 1 μ s.	External GPS signal input, with 1 μ s accuracy
Digital inputs	5+5 contacts, dry or wet, or 8+8 contacts, wet	2 dry contacts
Digital outputs	Two relay contacts, plus 4 optional	Two relay contacts
Communication ports	Two 100 Mbits RJ45 Ethernet ports. One DB9 RS232 serial ports. One more RS232 port or one RJ45 MODEM. RS232 / USB converter One Ethernet port on the front	1 100Mbits Ethernet port 2 x RS232 serial ports
Optional IEC61850- 8 communication with substation protection/ automation System	One of the two ETHERNET ports can be selected to support this communication.	No

Item	TDU-100E	TDU-100
USB	Type: USB, in the front. For fault data export to the flash disk drive	No
Local LCD display	Yes, graphic.	No
Remote TDU reset, configuration file downloading and uploading	Yes	No remote file download

The following table lists the key improvements of TAS-2100E with respect to TAS-2100.

Item	TAS-2100E	TAS-2100	Notes
Fault location	Support wide area fault location	Double end and Single end fault location only	See detailed description in 8.7
Graphics	Power system network and fault location, system configuration rendering and display.	No	See detailed description in 8.3
Configuration consistency examination	The system will compare input configuration parameters and the configuration file uploaded from TDU to check the consistency of substation name and line name. The system show the last set configuration parameters, even if not directly connected with the TDU.	No	See detailed description in 8.1
Power frequency fault current display	Yes	No	

Item	TAS-2100E	TAS-2100	Notes
Nature of disturbance analysis	The system can identify if the disturbance is caused by a fault, circuit breaker operation or lightning.	No	
Simulation of a fault in a line	TAS-2100E can remotely trigger TDU-100E at both ends of a line at preset times to simulate a fault: we can examine the system performances.	No	
Data query	TAS WEB allows any client to query data, without affecting the normal TAS software operation	No	

2. FAULT LOCATION PRINCIPLE

Travelling waves are voltage and current surges propagating along the power line, arising from power system disturbances such as fault, switching operations, and lightning. The travelling wave fault locator determines the distance to fault by measuring the time for the surge to travel from the fault to the substation bus. Since 1950s several practical fault location methods have been proposed.

2.1 TYPE D (DOUBLE ENDED) METHOD

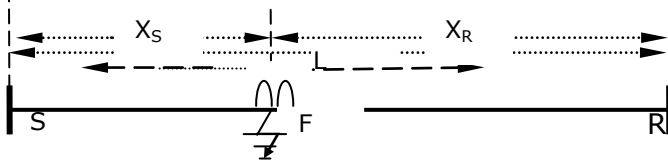

In Type D Method, units at both ends of a line are synchronized in time, and the arrival time tags of fault generated surges are recorded at both ends. The fault distance is determined measuring the difference of the arrival times.

$$X_S = [(T_S - T_R) \cdot v + L] / 2$$

$$X_R = [(T_R - T_S) \cdot v + L] / 2$$

- T_S and T_R are the absolute time of detecting the fault generated surges at the end of the line.
- v is the velocity of the travelling wave, which is close to the speed of light in overhead lines.
- L is the total length of the line.

Type D Method is the used method, other methods are used in special instances.

2.2 TYPE A (SINGLE ENDED) METHOD

Type A Method determines fault distance by analyzing the fault generated travelling wave surge waveforms recorded at one end of the line. The distance is computed by measuring the time difference Δt between the first surge and the second one, which is the round trip time for the pulse from the line end to the fault.

$$X_L = \Delta t \times v/2$$

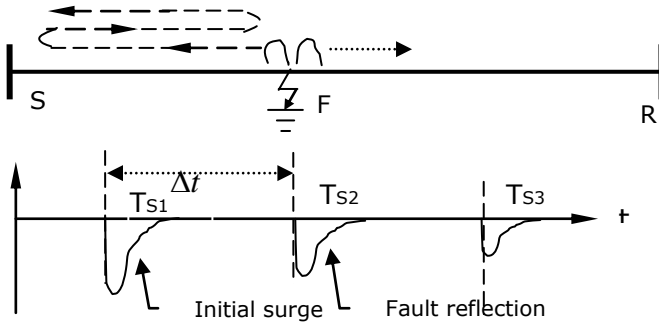

2.3 TYPE E METHOD

Type E Method makes use of transients generated when a circuit breaker is closed to a faulty line. The time interval between the first pulse created by CB reclosing and the reflected pulse from a short circuit or conductor broken fault is used to calculate the distance to fault.

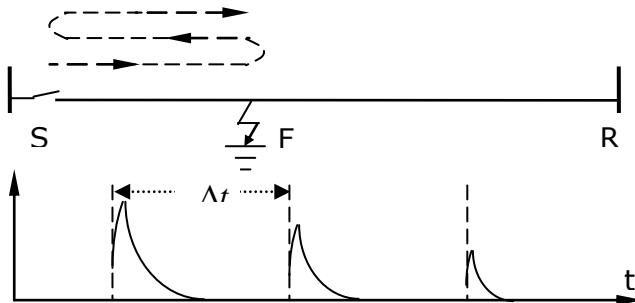

Faulty conductor waveform.

2.4 TYPE W (WIDE AREA) METHOD

The Wide area method identifies the faulty line and calculates the distance to fault based on time tags of travelling wave records of multiple substations across the network. Type W method provides backup fault location results when the TDU-100E at one end, or even TDU-100Es at both ends of the faulty line, failed to capture the fault waveform.

The principle of wide area fault location is described as following.

- 1) Find the substation that first detected the travelling wave surges, and select this substation as the reference one.
- 2) Find all substations that detected the travelling wave surges at the same time or after, with respect to the reference substation. These substations are named as subsequent substations.
- 3) For each subsequent substation, calculate the distance to fault using Type D Method, based on the time tags of surges detected at the substation with respect to the reference one. The shortest electric distance between substations is used as the length of the line, to facilitate the fault location calculation.
- 4) For each calculated fault location, find the time for a surge to travel from the fault to all substations which have detected the travelling wave surges through digital simulation.
- 5) The location with respect to which the simulated time tag pattern matches the TDU records is recognized as the actual fault location.

The first example is the one of a T shaped line.

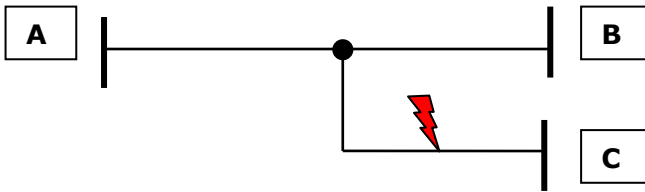

When a fault occurs in the position as shown, the associated impulses will travel to the right, towards TDU C, and to the left. When the impulse reaches the joint, it splits in two, and reaches TDU's A and B.

Just as an example, time stamps will be: 20 μs at C; 60 μs at B; 100 μs at A. Based upon these timings, the fault would be located as follows:

- At the joint, considering TDU's A and B;
- At the fault location, considering TDU's A and C, or B and C.

The wide area fault location understands the situation, and correctly locates the fault at its actual position.

Let us consider also the following example.

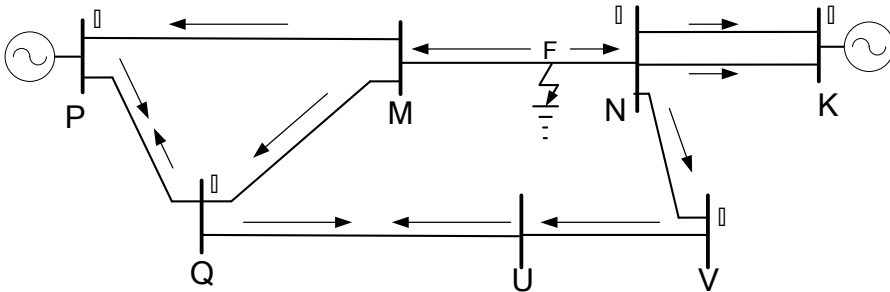

Propagation of fault generated travelling waves across a power network

Take a fault on line MN, and assume that the TDU-100E in substations N, K, V, P, Q (marked ⊗) have detected the fault surges. Substation N detected the surge first, and it is selected as the reference substation. Substations K, V, P, Q detected the fault surge later, and are called subsequent substations.

Using time tags of these four subsequent substations and of the reference substation, two possible fault locations can be identified: one at the bus of substation N, according to the time tag in substations K and V, and the other one on location F of the line MN, according to the time tag in substations P and Q.

The software computes the propagation times of the two fault locations, and finds the time tag pattern for a fault in N and F respectively. For a fault in N, the TDU-100E at substations P and Q have much delayed time tags, while a fault in F generates the same (well approximated) time tags. Therefore location F is recognized as the actual fault location.

2.5 APPLICATION OF DIFFERENT METHODS

Type D method is the one currently used, and has been proved to be excellent in accuracy and reliability in field operations.

Type E method is very efficient to locate a conductor broken fault.

Type A method is more cost effective, but its reliability is compromised by the difficulty to discriminate fault reflections from pulses introduced by reflections from other line terminals and the nonlinearity of fault arc, which does not affect the D method.

Type W method provides backup fault location results in case that the TDU in one end, or even two TDUs at both ends of the faulty line, failed to capture the fault waveform.

TAS-2100E employs Type D method as the fault location principle, while Type A, Type E and Type W methods are adopted as complementary fault location means.

3. MEASUREMENTS OF TRAVELLING WAVES

Travelling waves can be detected by monitoring the fault generated transient voltage or current signals at substation buses. We examine now the solutions for the different type of lines.

3.1 AC POWER LINE

The conventional CT accurately reproduces the primary current transients on its secondary winding; this provides a simple and cost-effective method to detect travelling waves on AC power lines.

3.1.1 More than one line on the bars

Besides the faulted line, the AC power line bus usually has more than one line connected, and this causes a sharp reduction of the impedance seen by travelling waves. The travelling wave is reflected and increased by this reduction; thanks to this fact, the TDU can easily detect the current transient when the fault surge arrives: this ensures high detection sensitivity of the travelling wave.

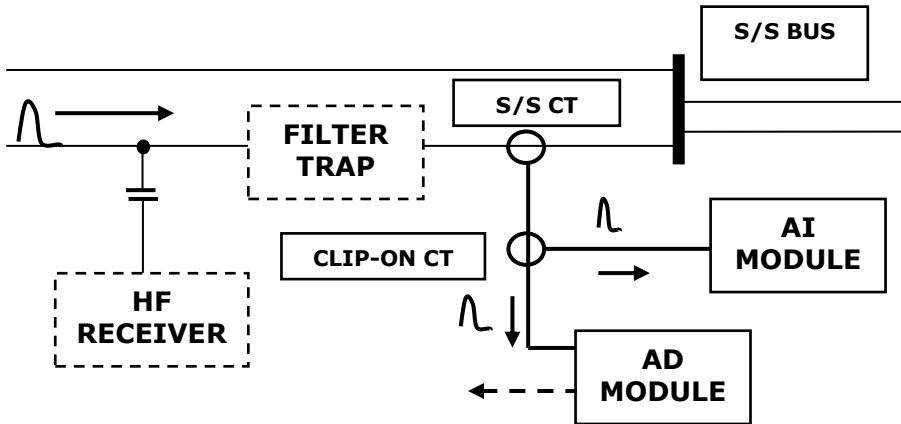

The ideal case is when many lines leave the bus bar, because all of the impulse is reflected.

NOTE. Sometimes in the substation it is installed a capacitors battery, which is usually directly connected to the bus-bars. This improves the detection sensitivity.

NOTE. The presence of a filter trap before the CT, shown dashed in the above diagram, does not affect the TDU operation. In fact, the wave impulse has a wide range, from 1 kHz to more than 100 kHz, while the filter trap has a very narrow bandwidth.

3.1.2 One line on the bars

If only the faulted line connected to the bus, as, for instance, in the case of a generating substation, where the step-up transformer is connected to the bus, the current wave is completely nulled by the total reflection of the high impedance. In this instance, the system measures the voltage transient, using the conventional (inductive) voltage transformer (VT).

The same configuration is used when there is only one leaving line, and it is wished to record the fault even in the case that it is open.

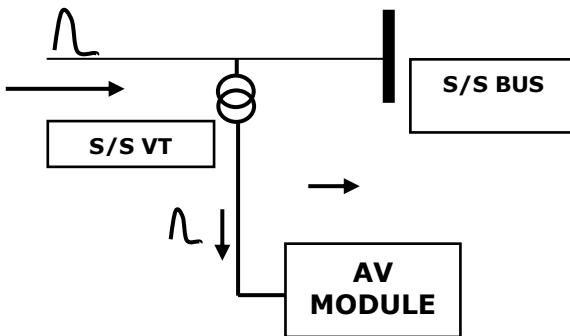

Measuring the voltage impulse can be impossible when the voltage transformer is not inductive, but it is a capacitor divider voltage transformer (CVT), as it is normally used in Extreme High Voltage (EHV) transmission systems. The CVT is a tuned circuit, has an inferior voltage transient response, and is a shunt for the current impulse. In this case, that is, only **one line on the bus plus CVT**, the transient should be acquired indirectly, by measuring the transient current through the earth wire of the coupling capacitor using an external CT.

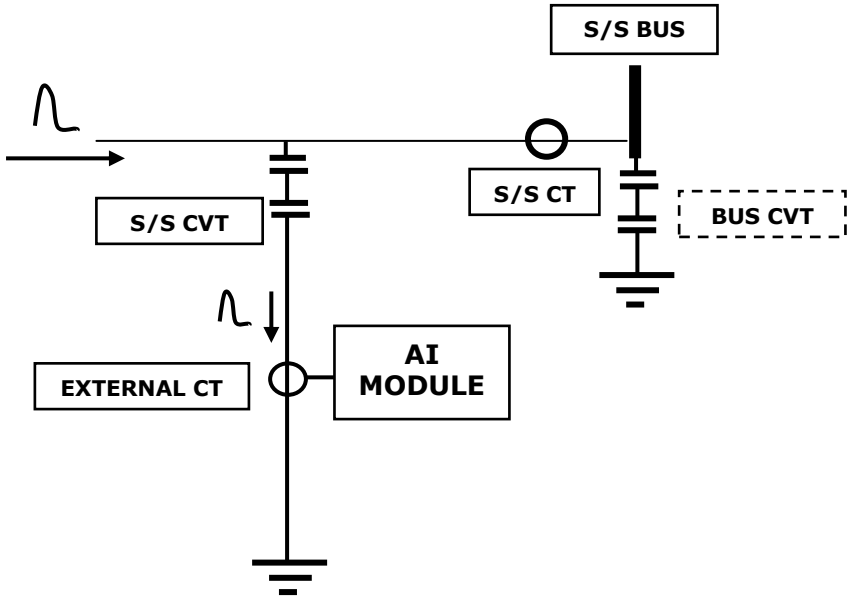

NOTE. If there is a second CVT on the bus, then the current impulse divides between the two CVT's, and the current impulse can be detected, as usual, on the CT secondary side.

In summary, see the following table.

LINES	CVT	MEASURE	MODULE
MORE THAN ONE	--	CT secondary side	AI + CT (or AD)
ONE	NO	Voltage	AV
ONE	YES	Ground connection of S/S CVT	AI + external CT
ONE	Second CVT on bars	CT secondary side	AI + CT

3.2 HVDC TRANSMISSION LINE

On HVDC transmission lines, transient impulses should be acquired indirectly, by measuring the transient current through the earth wire of the surge suppression capacitor or carrier coupling using an external CT.

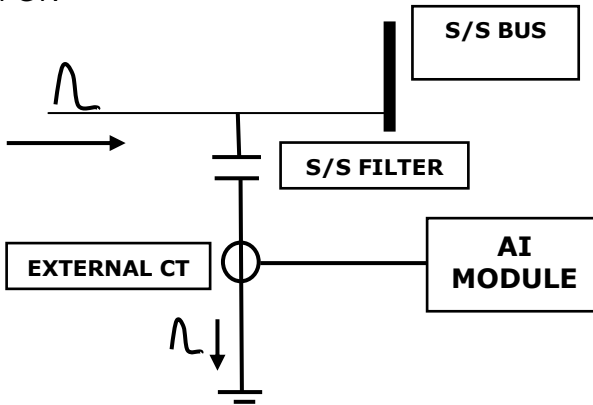

4. SYSTEM DESCRIPTION AND PERFORMANCE

The fault location system TFS-2100E consists of:

1. **TDU-100E:** travelling wave data acquisition unit.
 TDUs are installed at substations, and each TDU can monitor up to 8 lines;
2. **TAS-2100E Master Station software:** Travelling wave analysis software.
 TAS runs on the master station PC (not included in the supply), deployed in the control center, and the communication network.

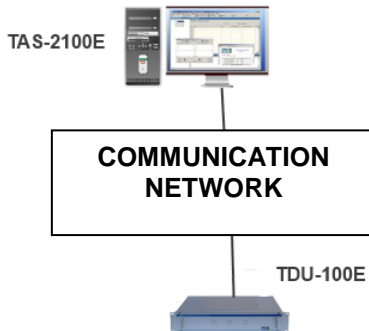

TDU-100E also synchronizes with the Global Positioning System (GPS) in time to provide accurate time reference. The GPS signal can be acquired from substations via the IRIG-B interface, or via a direct connection to GPS; optionally, TDU-100E can host a GPS time synchronizer (100 ns relative to 1 μ s).

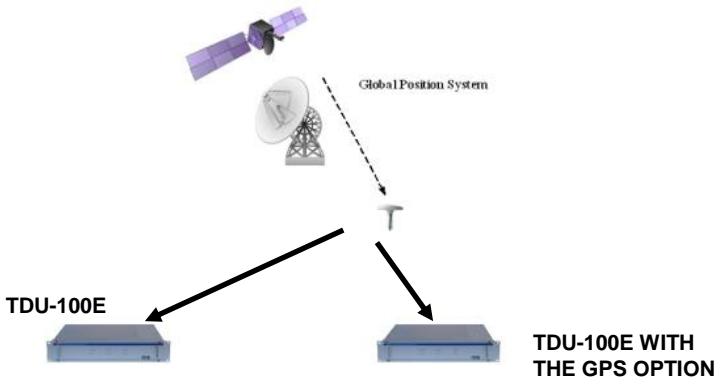

4.1 TRAVELLING WAVE DATA ACQUISITION UNIT TDU-100E

TDU-100E is designed to acquire fault travelling waves in DC/AC transmission lines and transfer the data to the master station for fault location. It continuously samples the secondary output of CTs or VTs and stores the sampled data in a circular memory buffer.

When the unit is triggered, i.e. the deviation of any input signals exceeded the pre-set threshold level, the embedded super-high speed Data Acquisition Unit (DAU), which is independent of the mastering unit, records and saves the transient travelling wave signal in real time.

The pre-fault buffered data and the transient data, in a pre-set time frame, are transferred to the non-volatile memory. The acquired data are then sent to the master station via the communication network for further processing.

Our special interface control technique reduces the time interval between recording two subsequent travelling waves to less than 200 μ s. With this approach, we can guarantee seamless recordings of transient signals, avoid losing fault waves.

The configuration of TDU-100E can be viewed and modified by the TAS-2100E software. This software can also be used to export travelling wave records from TDU-100E, to display waveforms, and to upgrade the firmware of TDU-100E.

4.2 MASTER STATION SOFTWARE TAS-2100E

The travelling wave analysis software TAS-2100E runs on the master station PC in windows® environment. TAS-2100E collects the transient data acquired by the TDU-100E travelling wave data acquisition units installed at the substation, and calculates the distance to fault automatically by the double-ended (Type D) method. It also allows users to view the transient waveforms and to compute the distance to fault by identifying reflections from fault.

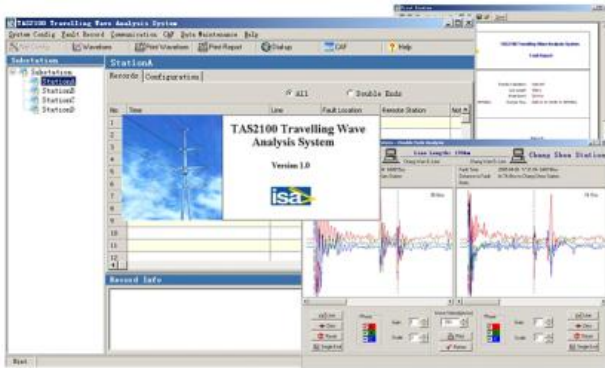

The software has a second module, called TAS WEB, which allow clients to read transient data via any WEB browser.

4.3 TFS-2100E SYSTEM PERFORMANCES

The TFS-2100E system, consisting of TDU-100E and TAS-2100E, has the following features.

4.3.1 Performances in normal operation

The TFS-2100E system will perform all defined functions properly, even in the following events:

- Switching on or off a line;
- Switching a Transformer;
- Switching an inductance;
- Switching a cable;
- Switching a capacitor.
- The induced voltage and current due to the operation of parallel lines.

TDU-100E has passed the level IV EMC tests conforming to IEC standards, and will not be affected by the electromagnetic interferences generated by the above events.

The surge current in transmission lines generated by switching operations may trigger the TDU-100E to record transient signals. However, the TFS-2100E can clearly distinguish switching operations from faults in power systems by examining the magnitude of power frequency harmonics of the recorded current.

4.3.2 The impact of harmonics variations

TDU-100E is designed to be triggered by high frequency travelling wave surges generated by fault. The harmonics and variations of power frequency will neither trigger the TDU-100E nor affect the TDU-100E to capture travelling waves of faults. Therefore, the harmonics and frequency variations will not have any impact on the performance of TDU-100E.

The power swing will cause the oscillation of transmission line current. However, the variation of current during power swing is too slow to trigger TDU-100E, and therefore will not have undesirable impact on the performance of TDU-100E.

4.3.3 Critical operation condition

TDU-100E has passed voltage dip and short interruption tests conforming to EN61000-4-11; therefore, slow declines and temporary interruptions of the auxiliary power supply will not cause TDU-100Es to be malfunction.

4.3.4 Fault location accuracy

TAS-2100E calculates the distance to fault using time tags of fault generated surges. As the propagation time of travelling waves is free from influences of fault resistances, line transpositions, couplings between lines, fault types, and the evolution of fault, it is capable to locate the fault with the accuracy of one tower.

4.3.5 Network configuration

The fault location accuracy of the TFS-2100E system is the same also in case of overhead lines with inhomogeneous impedance or double circuit lines, as the velocity of the travelling wave is identical to the one of single homogeneous overhead line.

The fault distance calculation method accounts the velocity difference between overhead lines and cables, and therefore the fault location accuracy of overhead and cable mixed lines can also be guaranteed.

For the line with T branch, it is required that TDU-100E is installed in each end of the line section to offer correct fault location in the entire line.

TAS-2100E computes fault locations by detecting and comparing the arrival time of fault generated travelling wave surges. In principle, it requires the TDU-100E to be installed in both ends of the line. However, it is possible to reduce TDU-100E installations, depending upon the specific network configuration.

Taking the network shown in the following figure as an example, the fault in the entire network can be located by using time tags of fault surges detected by TDU-100E in substations A and C only.

TDU-100E does not need to be installed in substation B or D. This is because travelling wave surges generated by all faults in any line of the network can be detected by the TDU-100E in substation A and C, and can be used to calculate the distance to fault.

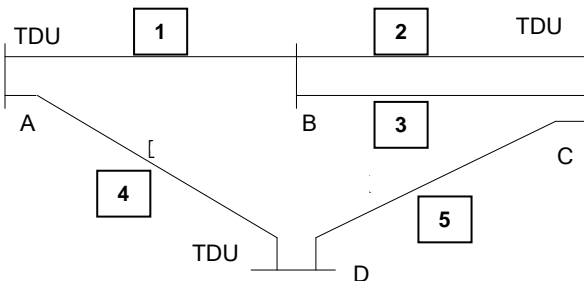

Note that it is possible to locate a fault in line 3 with respect to line 2. In fact, TDU-100E can identify the faulty line and phase by examining and comparing the magnitude of the fault current at 50/60Hz. For example, if the fault is on line 2, the 50/60Hz fault current of line 2 is certainly greater than the fault current of line 3. The 50/60Hz fault current component of line 2 and 3 can be calculated from the travelling wave record of TDU-100E in substation C, provided that the length of record is equal or greater than 10ms.

For the network shown in following figure, four TDU-100E, installed in substation A, C, D, and E respectively, can identify the locations of all faults in line 1 to line 6.

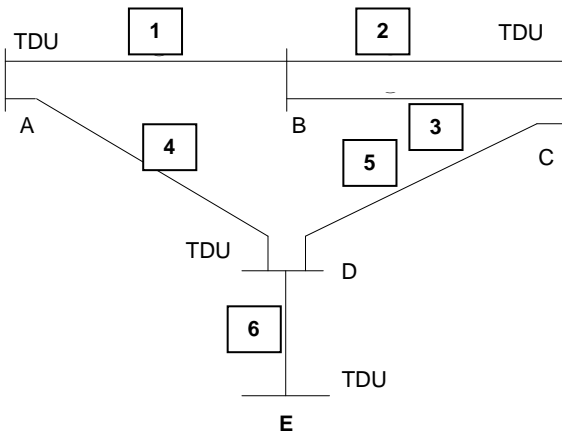

4.3.6 Fault resistance sensitivity

TDU-100E is designed to trigger with high resistance faults. The typical fault resistance which is detected by the system is 1000 Ohm. Considering that a burden resistance ranges between 100 and 300 Ohm, this means that TDU-100E triggers with fault values three times greater than the maximum burden.

4.3.7 System organization

TDU-100E has two main communication ports: one, called the master station port, to communicate with TAS-2100E in the control center, and the other one, called the supervisory port, for integrating the remote monitoring or the remote operation.

The supervisory port is used to connect the TDU-100E to

- 1) the SCADA system in the control center;
- 2) the RTU in the substation which will act as a gateway between the TDU-100E and SCADA system;
- 3) the TAS2100E master station in the substation which communicate with all TDUs in the substation and perform TFS substation monitoring and control.

The Information which TDU-100E can get from the ports are:

- 1) Signals to start the fault data retrieving.
- 2) Reset command for TDU-100E.
- 3) Configuration parameters for TDU-100E.

The information that TDU-100E sends out through the ports are:

- 1) Recorded triggering signal.
- 2) Travelling wave record summary, including: time tag, power frequency fault current, etc.
- 3) Alarm signals, including internal hardware failure, GPS synchronization signal lost, etc.
- 4) Configuration parameters.

TDU-100E has two Ethernet ports and each one can be assigned as a supervisory port. The supervisory port optional supports IEC61850-8 data and information exchange models.

4.4 TFS-2100E FUNCTIONS AND FEATURES

In the following main functions and features of TFS-2100E are listed.

1. TFS performs automatic calculation of distance to fault using double-end and wide area fault location methods with errors smaller than 50m. It also provides tools to allow the operator to analyze travelling wave time tags and waveforms and to determine the distance to fault.
2. The fault location result is the distance from the substation to the fault (in km or in percentage of the total line length), or in the tower of the line.
3. The double-end method calculates the distance to fault based on time tags of travelling wave records acquired at both ends of the faulty line.
4. The wide area fault location identifies the origin point of traveling waves (the fault point) using time tags of travelling wave surges of multiple substations across the power network.
5. Sometimes, the double-end method cannot make decision if the line monitored is the faulty line; for instance, because the TDU-100E at the remote end of the line adjacent to the faulty line may also be triggered by the fault signal. With wide area fault location, it is possible to find the substation. This information is used to identify the faulty line where the transient is initiated.
6. TAS-2100E discriminates the nature of the recorded travelling wave disturbance by examining the magnitude of the power frequency current and status of circuit breakers (CBs). A fault will cause the current of the line exceeding a pre-set value, and will result in tripping of the circuit breaker. A normal CB operation will cause the current to change from zero to a value, or from a value to zero, and the current of the line will not exceed the setting value. A lightning will not change the power frequency current and the status of the circuit breaker remains unchanged.
7. Lightnings stroke on the line may also be able to trigger the TDU-100E, and TFS can indicate the lightning striking location, based on time tags of lighting surges. However, the discrimination between lightnings and faults is made by examining the magnitude of the power frequency current.
8. The faulty line and phase is identified by examining and comparing the three phase power frequency currents.
9. TAS-2100E automatically (can also be manually) collects the remote substation fault data, and stores them in the local data

base as soon as a fault is detected.

10. TAS-2100E performs fault records management, report preview and printing. It also provides the fault history and calculation result statistics and queries.
11. The system performs the simulation of a fault. TAS-2100E sends commands to TDU-100E at both ends of a line. Two TDU-100E start to record the input signal at preset times to simulate a fault on the line. They will send the recorded data to TAS-2100E to initiate a double end fault locating process.
12. The system has comprehensive self-diagnosis ability. The overall system performance can be examined by the simulation of a fault. TAS-2100E can also remotely trigger a selected TDU-100E, interrogate the recorded data and display the waveform to diagnose the system. The diagnosis software of TDU-100E can identify the failed hardware module and provides detailed diagnosis information, such as GPS signal lost, communication link broken, flash disk defect, etc.
13. TAS-2100E can upload, view, change the configuration of TDU-100E, and reset the device remotely.
14. TAS-2100E displays the single line diagram of power system networks. Users can view the travelling wave record index by clicking on a substation or a line element. The record can be viewed by selecting a corresponding record index. It can also display the diagram of a fault location system which shows the operation status of TDU-100E and of the communication channels.
15. TAS-2100E can publish data to other systems using the table file of the database, which provides the fault information, including name of the faulty line, fault occurrence time, fault distance. This allows these data to be written to another database, automatically after a fault. The TAS-2100E Database is based on SQL format.
16. TAS-2100E can send data to clients, using the WEB Service.
17. TAS-2100E can be interfaces with external system (for example SCADA) using the protocol DNP3.0 or, optionally, the protocol IEC61850.

5. COMMUNICATION

Three communication means are available: dial-up, point to point, TCP/IP network.

5.1 DIAL UP

TDU-100E and the master station are connected to the utility or to the public telephone network, using a modem which is integrated into TDU-100E. The transient data acquired by TDU-100E are sent to the master station by dial-up communication.

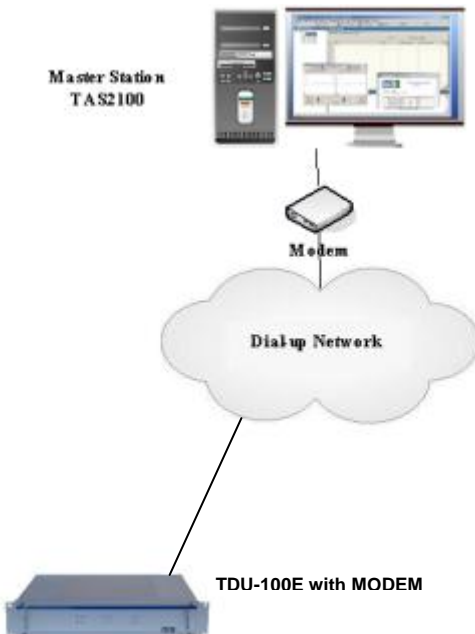

Any user can get data from TDU-100E, starting the TAS-2100E software and composing the TDU telephone number.

5.2 POINT TO POINT CONNECTION

TDU-100E and the master station are linked together through a dedicated point-to-point data transmission channel provided by optical fibers or microwave communication networks. Both of them are interfaced to the communication channel via an RS-232 port. The baud rate of the communication is 1,200 to 56000 baud per second, selectable depending on channel conditions.

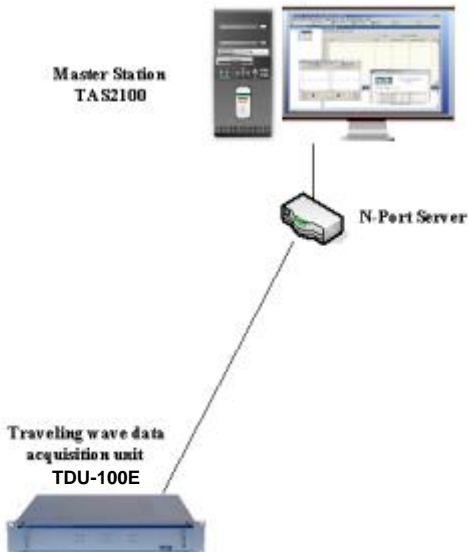

Any user can get data from TDU-100E, starting the TAS-2100E software and via the port server.

5.3 TCP/IP NETWORK

TDU-100E and the master station are connected to a TCP/IP network via their Ethernet ports. The TCP/IP communication method can support the following three connection system alternatives.

- The communication method between the master station and the substation is LAN; no further devices are required for the communication and data collections.

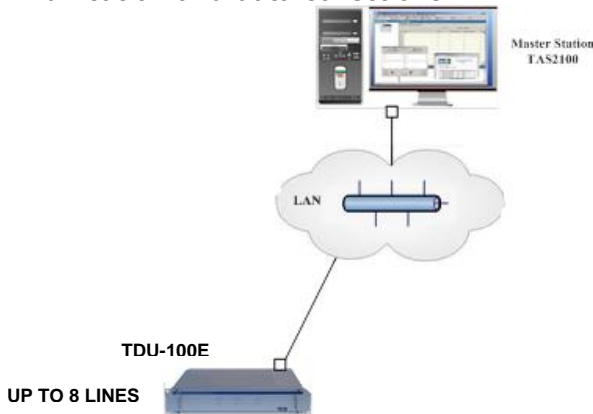

- The communication method in the master station is LAN, and in the substation it is WLAN; it is possible to use a router/gateway (not provided) with a port mapping function to connect LAN to WLAN.

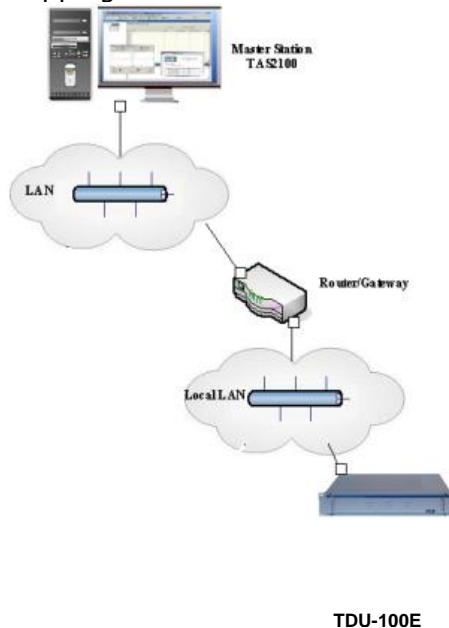

- All TDU-100Es installed in the substation are directly connected to the master station.

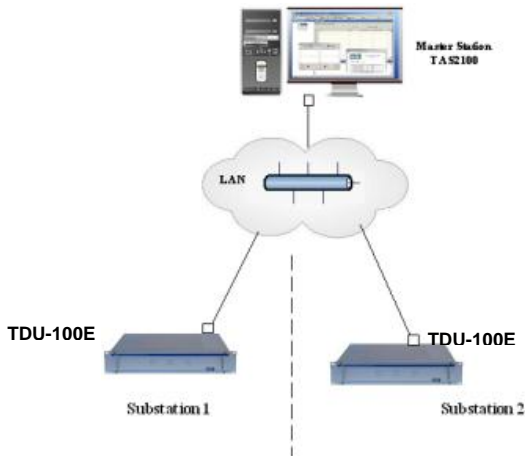

Any user can get data from TDU-100E, starting the TAS-2100E software and selecting the TDU-100E address.

6. TDU-100E SPECIFICATIONS

TDU-100E is a 2U rack module, which hosts up to 14 modules. In the following, you can find the description of the modules. The unit can vary in composition according to your needs, as shown at the end of the paragraph.

The following is a picture of TDU-100E.



- 2U, 19" rack.
- Dimensions: 483mm×323mm×88 mm.
- Weight: <4kg without modules; < 6 kg with modules.

6.1 FRONT PANEL

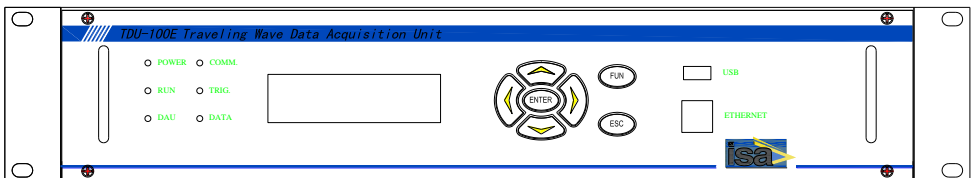

The front panel hosts the following components:

- Six status LED lights (optionally: seven);
- One LCD display;
- Five push-buttons for interface operations;
- An ESC button to exit the current menu and a function button for the menu data selection;
- One USB port for USB flash drives. It allows to export fault records and configuration files to a USB flash drive;
- An interface connector, type RJ45, for local connections. An RS232 / USB converter is supplied to have the possibility to use this port with the last PC generation that have no more the RS232 port.

The following LED indications are displayed in the front panel:

- **Power:** green for normal operation.
- **Run:** green for normal operation, and red for internal failure. It blinks once per second when the unit operates correctly.
- **Sync.** It blinks once per second, when TDU-100E receives the GPS synchronization signal correctly. It stops blinking when the GPS signal is lost.
- **Comm.** It is blinking when the communication is in progress.
- **Trigger:** it blinks once, during 3 s, when TDU-100E is triggered by a travelling wave surge.
- **Data:** green when a new travelling wave record is ready. It is off when the records have been pulled out by the master station.
- **DAU** - Optional LED: green for normal operation, and red for internal failure. It blinks once per second when the Digital to Analog conversion Unit operates correctly.

The front panel also hosts the microprocessor, the main memory and the control logic.

The set-up parameters of TDU-100E can be viewed and programmed on the display, or from the PC.

- TDU-100E configuration. It includes the following information:
 - Substation and line identification;
 - Date and time;
 - Line characteristics (type and length);
 - Type of connection: split-core CT, direct connection to the CT via an external CT, voltage transformer;
 - Sampling frequency;
 - Length (time duration) of records;
 - Trigger delay time (the time interval between two records);
 - Ratio of CT or / and PT;
 - Gain of analog channels;
 - Trigger threshold;
 - Trigger setting.

- TAS-2100E Data recovery.
 - Fault records are immediately stored into the TDU-100E huge non-volatile memory.
 - Records are automatically delivered to the monitoring system (ETHERNET connection).
 - Historic data can be asked from the monitoring system.
 - During the recovery, in case of transmission problems, the TAS-2100E software automatically performs retries; after 10 retries, an alarm is displayed and sent to the monitoring system.

- TAS-2100E Data management.
 - The operator can view the list of recordings saved into one or more TDU-100E. The list can be explored in many ways: date, location, alphabetic order.
 - The operator can select and call at the meantime one or more recordings coming from more than TDU-100E (for instance, the two at the end of the same line); maximum number 200 equipment.
 - The operator can edit or delete the recordings, after confirmation.

TDU-100E continuously performs the self-control of the equipment. The following alarm information can be displayed in the LCD:

- GPS signal lost;
- TDU-100E triggered;
- Communication link broken;
- Hardware module failure, including: power supply module, comm. module, time sync. module, DI module, AI and AD module, DAU module, CPU module;
- Failure of the flash disk for data storage.

The 48 latest travelling wave fault information can be viewed in the display, including time tags, power frequency current.

Alarms can also be viewed by the TAS-2100E Master station software.

6.2 DEVICE CHARACTERISTICS

6.2.1 A/D conversion

- Located into the main unit.
- Sampling frequency: 36 MHz (one conductor), 12 MHz, 8 MHz, 6 MHz, 4.8 MHz, 4 MHz, 3 MHz, 2.4 MHz, 1.5 MHz, 1 MHz, 500 kHz, user selectable; default 2 MHz.
- Resolution: 12 Bits.
- Clock accuracy: better than 1 ns.
- Clock drift: less than 1 ppM/year.
- The maximum sampling frequency is a function of the number of channels.
 - 36 MHz, for 1 channel.
 - 12 MHz, for 1 line with 3 channels (1 module).
 - 6 MHz, for 2 lines with 6 channels (2 modules).
 - 4 MHz, for 3 lines with 9 channels (3 modules).
 - 3 MHz, for 4 lines with 12 channels (4 modules).
 - 2.4 MHz, for 5 lines with 15 channels (5 modules).
 - 2 MHz, for 6 lines with 18 channels (6 modules).
 - 1.5 MHz, for 7 lines with 21 channels (7 modules).
 - 1.5 MHz, for 8 lines with 24 channels (8 modules).

6.2.2 Location accuracy

- Location accuracy: location error smaller than ± 50 m. It depends upon the accuracy of time synchronization (100 ns), and the accuracy of input parameters: the length of the line and the velocity of travelling waves.
- Maximum location resolution: ± 5 m. It depends upon the maximum sampling frequency of the A/D conversion.

6.2.3 Trigger

- Trigger threshold: The threshold range is 4% up to 20%, with step of 1%, user selectable. The default value is 8% of the maximum fault current, or the voltage surge.
- Minimum interval between two triggers: 10 ms, 20 ms, 50 ms, 100 ms, 200 ms, 500 ms, 1 s, user selectable; default: 200ms.
- Trigger date and time resolution: 0.1 μ s.

6.2.4 Length of transient recording

- 1-20 ms, programmable; default 1 ms.
- The device measures the power frequency fault current, independently from the record length.
- Fault transient memory, before the transmission to the interface processor.

6.2.5 Data storage

- Protected in case of power supply loss.
- Internal 8 GByte Flash disk.
- Number of records stored: 5000, 4000, 3000, 2000, 1000, 500, user selectable; default 1000.
- The conditions for 5000 records storage are: 24 channels, 1.5 MHz sampling frequency, and 20 ms recording duration.

6.2.6 Recording content

- Substation and line name;
- Date and time;
- TDU-100E name and serial number.

6.2.7 Self- diagnostics

- Watch dog: all interventions are recorded with date, time, and all relevant information.
- Continuous monitoring of: power supply, GPS signal, communication link, conditions of all hardware modules including power supply module, comm. module, time sync. module, DI module, AI and AD module, DAU module, CPU module and flash disk.
- No interference with the normal operation.
- Alarms are available on the front panel display, and on the interfaces.
- In case of internal fault, the test set sends information of the intervention to be performed via the local interface. The information is at the level of the module to be replaced.
- Alarms on two contacts, located on the power supply module. Optionally, four more alarm contacts on the DO module.

6.3 REAR PANEL

The rear panel gives access to a number of slots, where can be accommodated the modules which make TDU-100E. The choice has to be done at order, because also the TDU-100E slots position changes accordingly.



You can accommodate, left to right:

- The power supply module;
- The communication module;
- The TIME SYNC module;
- One or two digital inputs modules;
- One DO module;
- A maximum 8 AI modules for 24 analog channels, or maximum 4 AD/AV modules for 12 analog channels, or a combination of them.

6.4 MODULES CHARACTERISTICS

6.4.1 Analog Inputs modules

This modules serve to perform the measurement of the transient wave impulse. Three types of modules are available: AI, AD, AV.

- TDU-100E can accommodate at maximum 8 single width (25mm) modules (AI type) or 4 double width (50mm) modules (AD and AV types). To be specified at order (see later on).
- Channels: 3 to 24, configurable for 1 to 8 lines. Every module has 3 channels (one line).
- Type of inputs. In add to the three types of inputs modules (AI, AD, AV), there are two types of secondary current transformers (clip-on or external) to get the signal by the field.

A) **Module type AD.** Direct current input connection from the substation protection CT; it accepts 1 A or 5 A secondary currents. The selection is performed by a jumper.

- B) **Module type AI, plus a split core CT.** Current input through a split core CT, clipped on the substation protection CT's secondary side cable. This is the most used module. There are two types of split core CT's: 250T, for the 1 A secondary current, and 1250T, for the 5 A secondary current.
- C) **Module type AI, plus an external CT,** which comes with a protection box. The current allows for HVDC line monitoring and for the Capacitive Voltage Transformer used in EHV substations, indirect method.
- D) **Module type AV.** Voltage input from the substation VT.

Modules characteristics.

- **Type AD:** AC Current input from the substation CT.
 - Double width (50 mm) module.
 - Nominal current: 5A or 1A.
 - Burden: < 0.4 VA ($I_n = 5A$); < 0.1 VA ($I_n = 1A$).
 - Connection: via a screw terminator, which accepts a cross section of up to 6 sq.mm.
 - Overload withstanding: $400\%I_n$, continuous. $4000\%I_n$, 1s.

- **Type AI plus split core CT:** AC current input through split core CT.
 - Single width (25 mm) module.
 - Nominal CT secondary current: 5A or 1A; to be specified at order.
 - Burden: negligible.
 - Overload withstanding: $400\%I_n$, continuous. $4000\%I_n$, 1s.
 - CT ratio: 250:1 for 1 A rating, or 1250:1 for 5 A rating.
 - CT bandwidth: from 40 Hz to 20 MHz.
 - CT dimensions: 53 x 40 x 80 mm; hole diameter 35 mm.
 - CT shielded cable: cross section 0.35 sq. mm; length standard 5 m, optional 7 m, 10 m or 20 m.



- **Type AI plus external CT.** Current input through an external CT.
 - Same module as above.
 - Nominal secondary current: 5A or 1A; to be specified at order.
 - External CT ratio: 200:1.
 - External CT dimensions: 103 (h) x 80 (w) x 26.5(d) mm; hole diameter 44 mm.
 - Cable length: up to 2 km.
 - External protection box, included. Box dimensions: 250 mm (h) x 150 mm (w) x 120 mm (d).

- **AV module.** AC Voltage input from the substation VT:
 - Nominal primary: 57V/63.5V/69V (phase voltage).
 - Maximum permanent voltage: 120 V.
 - Burden: < 0.4VA.
 - Overload withstanding: 250% Un, 10 s.

- Gain of analog channel: 50%-200%, configurable; default 100%.

6.4.2 Binary inputs

The purpose of the binary inputs is to allow the unit understanding whether a trigger was caused by a lightning or by a CB operation. When there is a trigger, TDU monitors the programmed digital input. If the input has changes within 100 ms, then the event was caused by the CB operation; else, it was caused by a lightning.

- Four type of modules are available.
- Two slots, single width (25 mm).
- Standard module: five double inputs, dry contacts. Each input is isolated with respect to the other one.
- Option 1: five double inputs, wet contacts, with DC voltage from 35 to 140 V. Each input is isolated with respect to the other one.
- Option 2: 8 inputs, wet contacts, with DC voltage 125 V nominal. Inputs have a common reference.
- Option 3: 8 inputs, wet contacts, with DC voltage 250 V nominal. Inputs have a common reference.
- Optically isolated: 1500V DC.

6.4.3 Time synchronization

These modules serve to synchronize all TDU's to the same time, with the accuracy of 0.1 μ s with the internal time synchronization.

- At this location, there can be installed five different types of time synchronization modules: Internal GPS module, IRIG-B with copper or optical fiber connection; logic (1PPs) input, also with copper or optical fiber connection.
- Single width (30 mm).

● **Internal time synchronization**

The internal time synchronization module has a connector for the antenna, plus two outputs for other devices. The synchronization status is available on the front panel. With this option, TDU-100E features the following.

- **External time synchronization:** four modules are available.
 - Option A: IRIG-B DC, 5V level TTL (BNC) (standard offer). Used for a maximum distance of 90 m.
 - Option B: 1PPS input, 5V level TTL (BNC) + Serial time message input from GPS clock: RS-485. Used for a maximum distance of 90 m.
 - Option C: Optical IRIG-B (ST). Used for any distance between devices.
 - Option D: Optical 1PPS input TTL (ST) + optical serial time message input from GPS clock (ST). Used for any distance between devices.

Indication lights, on the front panel:

- Trigger;
- Synchronization.

Display:

- It displays the current time. When the equipment is operated via the front panel, it displays the setting mode.
- Type of display: graphic, LCD. Number of pixels: 256 x 64; dimensions 132 x 39 mm.

Synchronization Acquisition time:

- 90 seconds max (new installation).
- 90 seconds max with time and location changes.
- 45 seconds max reboot without location changes.
- 20 seconds max reboot after loss of power.

Antenna:

- Cover diameter: 100 mm; total height: 180 mm.
- It fits into a rod having a diameter of 32 mm; the free height should be 30 mm.
- Cable length: 30 m. Optional lengths: 40 m, 50 m, 60 m, 100m, to be specified at order.
- Connector: BNC type.
- The module comes with a surge arrester (lightning suppressor protective device), to be mounted on the antenna cable, which protects the device against lightning on the antenna, plus an additional cable, 3 m long.
- The material is ABS.
- The operating temperature range is from $-40\text{ }^{\circ}\text{C}$ to $+85\text{ }^{\circ}\text{C}$.
- The antenna may have snow on it, but it does not operate if it is completely covered of snow.



Antenna.



Mounting kit.



Surge Arrester

Time accuracy:

- Time synchronization accuracy:
 - Internal GPS module: 100 ns.
 - External synchronization: 1 μ s.

6.4.4 Communication ports

These ports are used to connect the TDU's of the network to the Master Unit, so that trigger data can be acquired and the fault can be located. They serve also for the device parameters set-up. The COMM module is 40 mm wide. Two types available: standard and option 1.

● The Standard module includes:

- Two RJ45 100MBit Ethernet ports: For network communications to the master station, SCADA, local communication to the substation RTU, and protection systems.
 - The two Ethernet ports support IEC60870-5-104 protocol for network communication to the Master Station or SCADA, and optional support the IEC61850-8 for local communication to substation RTU and/or to the protection system.
- One DB9 RS232 port for communications to the master station, SCADA, local substation RTUs, and protection systems.
 - 1.2 to 38.4 kbps baud rate.
 - It supports IEC60870-5-103 or DNP3.0 protocols.
- One RJ45 dialing in MODEM, for communications to the master station, SCADA, local substation RTUs, or protection systems.

● The Optional module includes:

- Two RJ45 100MBit Ethernet ports: for network communications to the master station, SCADA, local communications to the substation RTU, and protection systems.
 - The two Ethernet ports support IEC60870-5-104 protocol for network communication to the master station or SCADA, and optional support the IEC61850-8 for local communication to substation RTU and/or to the protection system.
- Two DB9 RS232 ports for communications to the master station, SCADA, local substation RTU, or protection system.
 - 1.2 to 38.4 kbps baud rate.
 - They support IEC60870-5-103, DNP3.0 protocol.

- The local RS232 connection cable is provided. It is 2 m long, terminated with a male and a female 9-way connector; the connection is of the crossing type (2 to 3 and so on). An RS232 / USB adaptator is provided to connect even PC of the last generation without RS232 port.
- The communication is based on TCP / IP protocols whose transport layer conforms to TCP and UDP and network layer is IPv4 (possible evolution towards IPv6). The TCP / IP suite supports RFC 1122. The physical connection interface is RJ45 type, complying with 802.3-2005 and IEEE 802.3ab standards.
- Option with IEC61850-8:
 - The following signals: Triggered, GPS lost, trigger time are transmitted using GOOSE messages.
 - ATTENTION: the Standard does not foresee the communication between different substations. As a consequence, the fault cannot be located with this Standard.
 - Transport protocol: MMS.

6.4.5 Power supply

The module serves to supply TDU, and also to provide two alarms.

- Characteristics:
 - Double width (50 mm).
 - Basic module. Voltage: 85 to 264V, 50/60 Hz AC or 90 to 260V DC.
 - Option 1: 35 to 140 V DC.
 - Option 2: 100 to 300 V DC.
 - Power consumption: <10W
 - Module hold-up: 200 ms, for the voltage going down to zero.
- The module includes two Dry contacts (normally open): ALARM, for abnormal operation; TRIGGER, for trigger lost alarm. In alternative, four alarms are available on the optional DO module.
- Contacts rating: 28 V DC/2 A, 140 V DC/0.4 A; 250 V AC/0.5 A.

6.4.6 Logic output DO module

The module allows generating up to four alarms, instead of the two available on the power supply module.

- The module, single width, includes four Dry contacts (normally open), which can be assigned an alarm function.
- Alarms are the followings.
 - TDU synchronized (GPS OK): it closes as TDU is synchronized.
 - Trigger TDU: it closes during 5 s when TDU triggers;
 - SD card: it closes if the card is wrong.
 - Spare.
- Contacts rating: 28 V DC/2 A, 140 V DC/0.4 A; 250 V AC/0.5 A.

The summary of all available modules, to be specified at order, is provided in Appendix 1.

6.4.7 Packing list

The following is the list of materials delivered with TDU-100E.

N.	Description	Q.ty
1	TDU-100E unit: it includes the following modules, 2 to 6.	1
2	Power supply module: basic, or one of the two options	1
3	COMM Module, one of the two types	1
4	Sync module, one of the five types	1
5	Digital Module: standard or options 1, 2, 3	1 or 2
6	Analog modules, types: AI, AD, AV	1 to 8
7	Split core CT transformers: three for each AI module; secondary current 1 A or 5 A	3 to 24
8	GPS antenna	1
9	Antenna cable, 30 m or option	1
10	Antenna assembly kit	1
11	Antenna surge arrester, plus cable 3 m	1
12	Serial RS232 connection cable, 9 pins, 2 m, with RS232 / USB converter	1
13	Local Ethernet connection cable, RJ45 to RJ45, 1.5 m	2
14	Power supply cable, 1,5 m	1
15	Fuse, T3A	1

16	TDU-100E manuals	3
17	TAS-2100E software, on CD	1
18	MODEM option: local connection cable, RJ11 to RJ11, 2 m	1
19	DO module option	0 or 1

6.5 EXAMPLES OF ANALOG CHANNELS CONFIGURATIONS

For example, in the following are explained five different analog channels configurations; they **should be specified at order**.

- **Configuration-1**, for up to EIGHT lines on AI modules.
 - POWER supply module: AC/DC power supply and two contact outputs. Choose among standard, option 1, option 2 types of supply.
 - COMM module. Choose between standard and option 1.
 - TIME SYNC module: Choose among internal GPS receiver or external synchronization signal inputs (four choices).
 - Spare room.
 - I/O modules: one or two, with five contact inputs each or option with 8 contact inputs.
 - Room for 8 × AI input modules: choose the number of AI modules.

POWER	COMM	TIME SYNC	SPARE	I/O-2	I/O-1	AI-8	AI-7	AI-6	AI-5	AI-4	AI-3	AI-2	AI-1
--------------	-------------	------------------	--------------	--------------	--------------	-------------	-------------	-------------	-------------	-------------	-------------	-------------	-------------

- **Configuration-2**, for up to FOUR analog inputs of AD or AV modules. As configuration 1, but:
 - Room for 4 AD or AV modules; choose the type and number of modules.

POWER	COMM	TIME SYNC	SPARE	I/O-2	I/O-1	AD / AV-4	AD / AV-3	AD / AV-2	AD / AV-1
--------------	-------------	------------------	--------------	--------------	--------------	------------------	------------------	------------------	------------------

- **Configuration-3**, for mixed analog inputs of up to 6 AI and 1 AD/AV module.

POWER	COMM	TIME SYNC	SPARE	I/O-2	I/O-1	AI-6	AI-5	AI-4	AI-3	AI-2	AI-1	AD / AV-1
--------------	-------------	------------------	--------------	--------------	--------------	-------------	-------------	-------------	-------------	-------------	-------------	------------------

- **Configuration-4**, for mixed analog inputs of up to 4 AI and 2 AD/AV module.

POWER	COMM	TIME SYNC	SPARE	I/O-2	I/O-1	AI-4	AI-3	AI-2	AI-1	AD / AV-2	AD / AV-1
--------------	-------------	------------------	--------------	--------------	--------------	-------------	-------------	-------------	-------------	------------------	------------------

- **Configuration-5**, for mixed analog inputs of up to 2 AI and 3 AD/AV module.

POWER	COMM	TIME SYNC	SPARE	I/O-2	I/O-1	AI-2	AI-1	AD / AV-3	AD / AV-2	AD / AV-1
--------------	-------------	------------------	--------------	--------------	--------------	-------------	-------------	------------------	------------------	------------------

If the composition is more complex, such as, for instance: 1 AD module; 2 AI modules, 2 AV modules, it is necessary to take into account the internal module cabling.

Modules have internal connections which are located in two different positions: AD and AV modules connections, which are wide, are located above the AI modules connections. In addition, the AD and AV modules connections are short-circuited to the first AI modules connections, as follows.

AD-AV	1	2	3	4	5	6	7	8
AI	1	2	3	4	5	6	7	8
CHANN	1	2	3	4	5	6	7	8

Connector 1 of the AD-AV modules is short-circuited to the connector 1 of the first AI module, which corresponds to the logic channel 1; channel 2 of the AD-AV modules is short-circuited to channel 2 and so on.

With the above case, the best module placing to minimize the number of channels is the following one.

AD-AV	1: AD	2: AV	3: NO	4: AV	5:	6:	7	8
AI	1	2	3	4	AI	AI	7	8
CHANN	1	2	3	4	5	6	7	8

Used channels are: 1, 2, 4, 5, 6.

7 SYSTEM CONFIGURATION

The configuration of the system depends upon the type of communication, being IP (or point-to point), or dial-up.

7.1 BASIC CONFIGURATION; IP CONNECTION

If the communication is IP or point-to-point, the Master unit and the TDU units are continuously connected; as a consequence, there can be only one Master unit, which will automatically collect all information from the various TDU's, and which will create a database containing all these information. Other users interested at these data, can:

- Connect to the Master unit as Clients, using any browser, and read all data of interest;
- Install TAS, and collect data as Database restore, or importing data from the Master unit. However, their PC address cannot be in the same range as the Master and TDU's.
- See the data using a Web interface with the software TAS-2100E WEB

The single-machine configuration is shown in the figure below. TAS-2100E and TAS-2100E WEB software are installed **in the Master computer only**. Other users, who want to access the system data, **don't need to install any software** (unless Java, if not already available).

The Master unit operator can set up the system to view travelling wave records and fault location results, analyze fault waveforms and execute the computer-aided fault location. Other clients can view the fault data, fault waveforms and fault location results by using any browser.

The Master Unit can also communicate to SCADA (or equivalent) supervisors via the DNP3 protocol or optionally via the IEC61850 protocol.

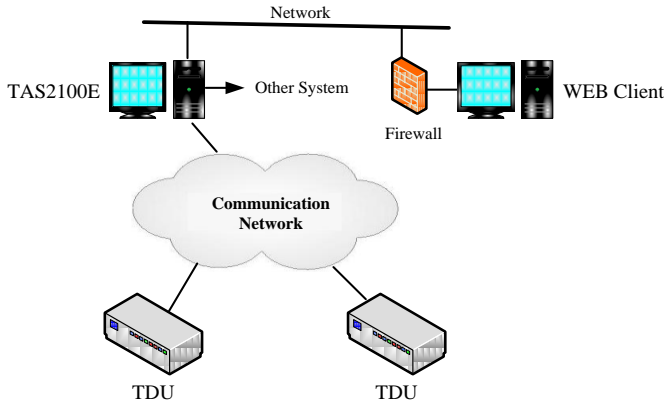

One machine Configuration

In alternative, if there are a number of regions not connected among them, it is possible to set-up TDU’s and TAS as follows.

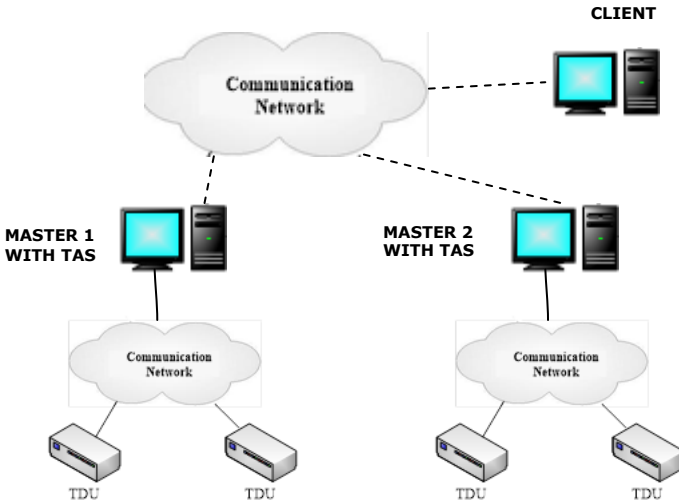

More than one master configuration

- For each region, there could be a dedicated master, which follows the network operation;
- All clients could access these masters:
- The drawback is that there would be four data base, instead of a single one with all results.

7.2 BASIC CONFIGURATION; DIAL-UP CONNECTION

If the communication is dial-up, then there is no direct communication between the Master unit and TDU's. So, in principle, the above limitation drops: there can be many PC's with TAS installed. The only problem is that two different PC's **should not call the same TDU at the same time.**

However, for the sake of clearness, it is advisable to adopt the "More than one master" configuration above, with a Master for each region. However, a Central office may have TAS installed, and access the various TDU's to make a single Database.

7.3 HARDWARE AND SOFTWARE REQUIREMENTS

With both configurations, the requests of TAS- 2100E are as follows.

- Minimum hardware requirements:
 - CPU: dual core 2.0GHz, or higher;
 - DRAM memory: at least 2 GByte;
 - Hard Disk: 500 GByte;
 - Monitor: 1024×768 pixels or 1600×900 pixels;
 - The mouse is required.
- Software:
 - Operating system : Microsoft Windows XP / 2008 / VISTA / Windows 7 / Windows 8, Professional Edition.
 - Database:
 - ◆ MySql 5;
 - ◆ Microsoft SQL Server 2008;
 - ◆ Oracle 12c.

7.4 TAS-2100E SOFTWARE SYSTEM ARCHITECTURE

The software system consists of communication modules, HMI modules, database service modules and WEB service modules. The functions of each module are as follows:

- **Communication Module:** To communicate with the travelling waves data acquisition unit (TDU).
- **Human-machine interface module:** To set up the system, view the fault data and fault location results, analyze fault waveforms and execute the computer-aided fault locator.
- **Database service module:** Management of historical relation database, supporting the management of cluster.
- **WEB service module:** WEB publishing of system.
- **Internal software data bus:** Used for data transmission between the communication module and the HMI module.

The software system architecture is shown in the following.

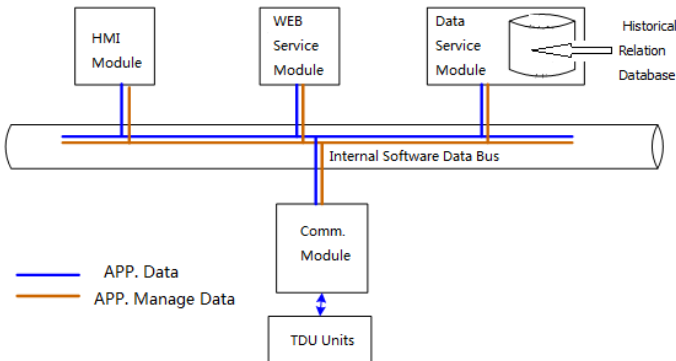

8. TAS-2100E FUNCTIONS DESCRIPTION

8.1 FUNCTIONS

Functions of TAS-2100E are listed in the following table. All these functions will not affect the operation of TDU-100E. TDU-100E will always be ready to detect and record faults, and will not be affected by software operations.

Table-2 Function list of TAS-2100E

Function	Description	Note
System management	Purview management	
	Configuration parameters	
	Parameter consistency checking	
	Fault simulation	
	Parameter export/import	
	Log	
	TDU-100E management	
Communication	TDU-100 management; no old data recovery	
	Versatile communications with TDU-100E	
	Communication protocol debugging	
	Manual retrieval of travelling wave records in TDU-100E	
	Remote configuration and reset of TDU-100E	
	Communication monitoring	
Graphics	TDU-100E alarm data browsing	
	Graphics rendering	
	Real-time data association with graphics	
	Graphics display	
	Network operation diagram	
Alarm	System operation diagram	
	Real time alarm	
	Historic alarm retrieval and search	
Data management	TDU-100E record data normalization	
	Data query	
	Fast waveform review	
	Nonvolatile storage of data	
	Data import and export	

Function	Description	Note
	Database Backup and Recovery	
Data analysis	Waveform analysis	
	Power frequency fault current analysis	
	The nature of disturbance analysis	
	Equipment status statistical analysis	
	Analysis of separate travelling wave records	
Fault Location	Double end automatic location	
	Wide area automatic location	
	Double end computer aided fault location	
	Double end fault location calculator	
	Single end computer aided location	
Google map	Support the fault location of mixed cable and overhead lines	
	Tower location input and modification	
	Fault point display on Google map	
Printing	Fault location and analysis report	
	Statistics printing	
Interface with external systems	Publishing system information using XML file	
	Publishing system information using table file of database	
	Publishing system information using WEB service	
	DNP 3.0 protocol interface	
	Optional IEC61850 protocol interface	

All operation of data monitoring are accessible from the system by a password. There are two password levels: one for data read only; the other one for configuration, data edit and delete.

8.2 SYSTEM MANAGEMENT

● **Purview management**

- Different level operators have different management authorizations to ensure system safety.
- Passwords are divided into the dispatcher password and the system maintenance password.
- Only the system maintenance password enables the operator to add, delete users and assign permissions to users.

● **Configuration parameters**

Configuration parameters are divided into system parameters and power system network parameters.

- System parameters include:
 - Server node parameters;
 - Database parameters.
 - Power network parameters include:
 - Region parameters. The system supports multiple regions monitoring. One substation only belongs to one region.
 - Substation parameter: substation name and voltage level.
 - Line parameters: Line name, length, wave velocity, A (left or upper)-side substation, B (right or lower)-side substation, being monitored or not.
 - Tower parameters: name, number, spacing, Maintenance Company. The parameters are used to display the fault between two towers. Support manually direct input and the Excel file importing.
 - Communication Channel parameters.
 - Channel names;
 - Communication ports;
 - The associated protocol.
- ### ● **Parameter consistency checking.**

The system will compare inputted configuration parameters and the configuration file uploaded from TDU to check the consistency of substation names and line names. The operator will be altered to establish a mapping between the TDU parameters and system parameters when the inconsistency is found.

- **Fault simulation.**

Possibility to command, locally or remotely, the simulation of a fault. TDU-100E will operate as recording a real fault, and creates all reports as in a real case. This function is for the diagnosis of the system operation status.
- **Export/import configuration parameters.**
 - To export and save system parameters and power system network parameters.
 - To import power system network parameters.
- **Log**
 - System events;
 - Communication channel events;
 - Operation events.
- **TDU-100E management.**
 - Device installation information: hardware revision, firmware revision, set-up parameters, and serial numbers.
 - Device maintenance information: causes of failure at the module level; historical books.

8.3 COMMUNICATION

- **Versatile communications with TDU**
 - Network IP communication using IEC60870-5-104 protocol
 - Serial RS-232 communication using IEC60870-5-103, DNP 3.0 protocol
 - Dialing modem communication using IEC60870-5-103, DNP 3.0 protocol
 - Optional: Ethernet communication using IEC61850 protocol
- **Communication protocol debugging**
- **Manual retrieval of travelling wave records of TDU**
- **Remote configuration and reset of TDU**
- **Communication monitoring**
 - Data transmission errors detection, channel fault detection
- **TDU alarm data browsing**
 - Equipment failure alarms, GPS signal lost alarm, triggered recording.

8.4 GRAPHICS

- **Graphics rendering**
 - Single line diagram of power system (network topology).
 - Fault location system configuration diagram.
 - Navigation map (index map).
- **Real-time data association with graphics**

Displaying real time data of substations, lines and TDU-100E in the diagram.
- **Graphics display.**
 - Two cursors for zoom in, zoom out, pan, bird's eye view.
 - Time scale display.
 - Display of the threshold level.
 - Display of the saturation limit, to check the selected gain.
- **Network operation diagram.**

Display the single line diagram of the power system network. User can view the travelling wave record index by clicking on a substation or line element. The record can be viewed by selecting a corresponding record index.
- **System operation diagram**

The software displays the diagram of fault location system, which shows the operation status of TDU-100E and of communication channels.

8.5 ALARM

- **Real time alarm**

Pop-up window alarm for: triggered recordings, watchdog faults, TDU-100E failures, GPS signals lost, and communication channel faults.
- **Historic alarm retrieval and search**

8.6 DATA MANAGEMENT

- **TDU-100E record data normalization**
To normalize travelling wave record data from TDU-100E to make the system compatible with various versions of TDU.
- **Data query**
To query the travelling wave record index, communication channel status, user operation records according to various conditions, such as region, substation, line segment and time.
- **Fast travelling wave waveform review**, after travelling wave record query.
- **Nonvolatile storage of data.**
- **Data import and export.**
 - Export the data to a flash disk for off line analysis, in a standard format.
 - Export and import travelling wave records to and from a flash disk in Comtrade-99 format.
 - Export and import the above to and from system database.
- **Database Backup and Recovery.**

8.7 DATA ANALYSIS

- **Waveform analysis.**
 - Single -end and double-end waveforms display and analysis.
 - Zoom in, Zoom out, Pan.
 - High pass and low pass filtering of the waveform.
 - Measurement of time difference or distance between the zero (reference) and moving cursors.
 - Measurement of waveform amplitude.
- **Power frequency fault current analysis.**
 - The analysis of the fault current at the mains frequency is performed when the buffer length is 20 ms.
- **The nature of disturbance analysis.**
The nature of disturbance (fault, circuit breaker operation, or lightning) is determined by examining the amplitude of power frequency current, which is extracted from 20ms travelling wave buffer.
- **Equipment status statistics analysis.**
- **Analysis of separated travelling wave records** which are stored in a hard disk, and were exported from TDU-100E.

8.8 FAULT LOCATION

- **Double end automatic fault location.**

The system calculates the distance to fault based on time tags of travelling wave records of both ends of the faulty line. The result is the distance from the substations, in km and in percentage of the total line length, and in the tower of the line.
- **Wide area automatic location.**

The system identifies the faulty line and calculates the distance to fault based on time tags of travelling wave records of multiple substations across network. It provides backup fault location result in case that the TDU-100E in one end, or even two TDU-100E at both ends of the faulty line failed to capture the fault waveform.
- **Double end computer aided fault location.**

The fault location is achieved by manually selecting the faulty line with time tags of fault record at both ends of the line.
- **Double end fault location calculator.**

The distance to fault is calculated based on the manually inputted time tags of travelling wave records at the both ends of the faulty line.
- **Single end computer aided fault location.**

The user analyzes the single end travelling wave waveform using the tools provided and determines the distance to fault.
- **Support the fault location of mixed cable and overhead line.**
 - In this case, is possible to input the different lengths and speed of light in the cable and overhead lines.

8.9 GOOGLE MAP

- **Tower location input and modification.**

The system provides HMI for tower location input or the modification of tower location information imported from Excel file.
- **Fault point display on Google map.**
 - The screen clearly displays which is the tower where the fault has occurred, with the latitude and longitude of the faulty point.

8.10 PRINTING

- **Fault location and analysis report.**
 - Fault location results.
 - Single end or double end travelling wave waveforms.
 - Substation name, line name.
 - Date, time.
 - TDU-100E serial number and name.
 - Line characteristics, name, length.
- **Report printing.**

Printing of various reports, such as travelling wave record index, fault location and alarm of regional network, a selected substation or line.

8.11 INTERFACE WITH EXTERNAL SYSTEMS

- Publishing system information using an XML file.
- Publishing system information using the table file of database.

8.12 OVERALL FEATURES

- Maximum number of substations: > 256.
- Maximum number of lines: > 1,000.
- Maximum number of travelling wave records: > 1,000,000.
- Master Station screen display swapping time: < 3 s.
- Data retrieval response time: < 3 s.

9 OPTIONAL TSG-10 IMPULSE GENERATOR

The purpose of the option is to allow the test of TDU-100E after the installation, when it is connected via the clip-on CT transformers. Device specifications are as followings.



TSG-10 dimensions



TSG-10 front panel

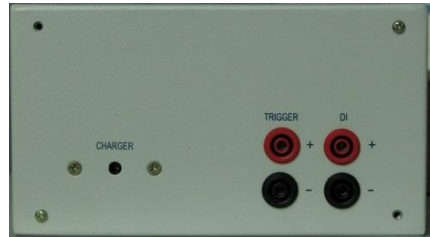

TSG-10 rear panel

Front panel description

- 1) DC ammeter: it displays the trigger pulse current peak
- 2) KNOB: trigger pulse current peak adjustment.
- 3) STEP: trigger pulse current peak range selection. Ranges are as follows.

STEP	Peak (mA)
1	100
2	200
3	300
4	500
5	700
6	1000

4) Lights: their meaning is as follows.

LED	Description
POWER	Light means that the device is working.
TRIG	Light means that the device is generating the output trigger pulse.
DI	Light means that the DIGITAL I/O module contact of TDU-100E is closed; no light means that the contact is open.
CHARGER	Light means that the device is charging

5) Functions switch (I / II / III)

Position	Description
I	Device is charging; the CHARGER LED is ON.
I I	Device is working, powered by the adapter. The POWER LED is ON.
I II	Device is working, powered by the battery. The POWER LED is ON.

6) Trigger button TRIG: as pressed, the current impulse is generated.

Rear panel description

1) CHARGER

This is the jack to connect the external charger.

2) TRIGGER

These are the TRIGGER output sockets.

3) DI

These sockets are provided for the connection to the output contact on DIGITAL I/O board of TDU-100E. Thanks to this connection, it is possible to check when TDU-100E senses the trigger impulse.

APPLICABLE STANDARDS

The following standards apply to all test sets of the TWS 1200 system.

A1 ELECTROMAGNETIC COMPATIBILITY

The test sets conform to the European Directive n. 2004/108/EC.
Applicable Standard: EN61326: 2006.

EMISSION

- EN 61000-3-3: Limitation of voltage fluctuations and flicker.
Acceptable limits: basic.
- CISPR16 (EN 55011 class A): Limits and measurement methods of radio-electric disturbances for industrial, medical and scientific instruments at radio-electric frequencies.
Acceptable limits for conducted emission:
 - . 0.15-0.5 MHz: 79 dB pk; 66 dB avg.
 - . 0.5-5 MHz: 73 dB pk; 60 dB avg.
 - . 5-30 MHz: 73 dB pk; 60 dB avg.Acceptable limits for radiated emission:
 - . 30-230 MHz: 40 dB (30 m)
 - . 230-1000 MHz: 47 dB (30 m)
- EN 55022 class A: Limits and measurement methods of radio disturbance for the Information Technology.
Acceptable limits for conducted emission at the mains port:
 - . 0.15-0.5 MHz: 79 dB pk; 66 dB avg.
 - . 0.5-30 MHz: 73 dB pk; 60 dB avg.Acceptable limits for common mode conducted emission at the telecommunications port. Voltage limits:
 - . 0.15-0.5 MHz: 97 to 87 dB pk; 84 to 74 dB avg.
 - . 0.5-30 MHz: 87 dB pk; 74 dB avg.Current limits (μA):
 - . 0.15-0.5 MHz: 53 to 43 pk; 40 to 30 avg.
 - . 0.5-30 MHz: 43 pk; 30 avg.Acceptable limits for radiated emission:
 - . 30-230 MHz: 40 dB (10 m)
 - . 230-1000 MHz: 47 dB (10 m)

IMMUNITY

- EN 61000-4-2: Immunity tests for ESD; test level 4. Test values: 15 kV in air; 8 kV in contact.
- EN 61000-4-3; Immunity tests for radio frequency interference. Test level 3. Test values ($f = 900 \pm 5$ MHz): field 10 V/m, modulated AM 80%; 1 kHz
- EN 61000-4-4; Immunity tests for high-speed transients (burst); test level 4. Test values: 4 kV (peak); 5/50 ns.
- EN 61000-4-5; Immunity tests for surge; test level 4. Test values: 2 kV peak differential mode; 4 kV peak common mode; 1.2/50 us.
- EN 61000-4-6: immunity to low-voltage sinusoidal waveform. Test level 3. Test values: 0.15-80 MHz, 3 V rms, 80% AM 1 kHz.
- EN 61000-4-8: Immunity tests for low frequency magnetic fields. Test level 5. Test value: 100 Arms/m.
- EN 61000-4-9: Immunity test for the pulse magnetic field. Test level 4. Pulse magnetic field strength, 5 positive, 5 negative, time interval < 10 s: 300 A/m.
- EN 61000-4-10: Immunity test for a damped oscillatory magnetic field. Test level 4. Oscillation frequency: 0.1 MHz and 1 MHz. Test duration: 2 s. Repetition rate: 40 transients/s at 0.1 MHz; 400 transients/s at 1 MHz: 30 A/m (peak).
- EN 61000-4-11: Immunity test for power supply dips. Test level 3. Test value: 25 cycles (500 ms); 70% drop; 10 cycles (200 ms); 0% drop.
- EN 61000-4-12: Immunity to damped oscillation waves. Test level 3. Test values: 2 kV common mode; 1 kV differential mode.
- EN 61000-4-16: Immunity to voltages at the mains frequency. Test level 4. Test values: 30 V continuous; 300 V 1 s.
- EN 61000-4-17: Immunity to ripple on the DC supply input. Test level 3. Test value: 10% of the nominal supply.
- EN 61000-4-29: Immunity to voltage dips on the DC supply. Test level: 4. Test values: 500 ms 70% drop; 200 ms 40% drop.
- EN 61000-4-29: Immunity to short interruptions to the DC supply. Test level: 4. Test values: 200 ms 0% drop.

A2 SAFETY

All devices conform to EN 60950-1:2006, low voltage directive, and to the European low voltage directive n. 2006/95/EC. Applicable standard: CEI EN 61010-1. In particular:

- Dielectric Rigidity: 1500 V (see the CEI EN 61010-1 standard).
- Isolation resistance: > 100 MOhm.
- Earth resistance: < 0.1 Ohm.
- Dispersion current: < 5 mA.
- Inputs/outputs protection: IP 2X - IEC 60529.

A.3 OPERATING CONDITIONS

- Operating temperature: - 10°C - 55°C; storage: -40°C to 85°C.
- Relative humidity: 0 - 90%, not condensing.
- Vibration: IEC 68-2-6 (20 m/s² at 10 - 150 Hz);
- Shock: IEC 68-2-27 (15 g; 11 ms; half-sine).
- Free fall: 25 cm.
- Altitude: less than 2000 m.

END OF LIFE

- TDU-100E does not include dangerous materials; in particular, PCB and asbestos materials.
- At the end of the life, the set should be disposed following the directive 2012/19/EU of the European Parliament, on Waste Electrical and Electronic Equipments (WEEE).

TDU-100E SELECTION FORM

The following form serves to define the TDU-100E modules, which are necessary for a given number of substations and lines that are to be protected.

N.	AREA	QUESTION	ANSWER
1	PLANT	Number of substations	
2	PLANT	For each S/S: number of lines to be protected	
3	PLANT	For each S/S: number of TDU-100E, and type of line (HV AC, EHV AC, DC) for each TDU.	
4	PLANT	For AC S/S: number of lines on the bus-bar (including the one to be protected).	
5	PLANT	In case of one line, type of Voltage Transformer: inductive or CVT. (If inductive, AV module; if CVT, external CT and AI module).	
6	PLANT	For each S/S: length of the lines to be protected	
7	PLANT	For each S/S: modules power supply	
8	LINE	For each line: nominal voltage	
9	LINE	For each line: CT primary and secondary currents	
10	MEASUREMENT	For each S/S. Case: AC line, more than one line on the bus. Do you prefer to connect the CT secondary directly to the TDU-100E analog input, or indirectly , via split core transformer (suggested; cable length 5 m; maximum 20 m)?	
11	SYNCHRONIZATION	For each S/S, specify if you want the GPS option or if you have available an IRIG-B synchronization or a 1PPS logic input (TTL or optical fiber: specify the type).	
12	SYNCHRONIZATION	Case: GPS option. For each S/S, specify the length of the cable from the TDU-100E module to the antenna (the standard cable length is 30 m)	
13	LOGIC INPUTS	Select the type of input module: standard (5 inputs, dry); option 1 (5 inputs, wet); option 2 (8 inputs, 125 V DC); option 3 (8 inputs, 250 V DC).	
14	LOGIC INPUTS	Select the number of input modules: 1 or 2	
15	LOGIC OUTPUTS	Select the optional DO module if you want more than two alarms	
16	COMMUNICATION	For each S/S, specify if TDU's are concentrated or distributed in kiosks	
17	COMMUNICATION	Case: kiosks. For each S/S, specify the distance between TDU's.	

18	COMMUNICATION	For each S/S, specify the type of communication inside the plant (dial up, point to point, TCP/IP), and between kiosks (if applicable).	
19	COMMUNICATION	Specify the connection of the Master Unit to the TDU-100E modules (dial up, point to point, TCP/IP).	
20	COMMUNICATION	Specify if you want the IEC61850-8 type of communication.	

Example: two lines line between two plants; TCP/IP communication.

N.	AREA	QUESTION	ANSWER
1	PLANT	Number of substations	2
2	PLANT	For each S/S: number of lines to be protected	2
3	PLANT	For each S/S: number of TDU-100E, and type of line (HV AC, EHV AC, DC) for each TDU.	S/S A: 1; HV AC S/S B: 1; HV AC
4	PLANT	For AC S/S: number of lines on the bus-bar (including the one to be protected).	S/S A: 2 S/S B: 2
5	PLANT	In case of one line, type of Voltage Transformer: inductive or CVT. (If inductive, AV module; if CVT, external CT and AI module).	---
6	PLANT	For each S/S: length of the lines to be protected	132 km
7	PLANT	For each S/S: modules power supply	110 V DC
8	LINE	For each line: nominal voltage	380 kV
9	LINE	For each line: CT primary and secondary currents	2000:5
10	MEASUREMENT	For each S/S. Case: AC line, more than one line on the bus. Do you prefer to connect the CT secondary directly to the TDU-100E analog input, or indirectly , via split core transformer (suggested; cable length 5 m; maximum 20 m)?	Indirectly, 5 m cable
11	SYNCHRONIZATION	For each S/S, specify if you want the GPS option or if you have available an IRIG-B synchronization or a 1PPS logic input (TTL or optical fiber: specify the type).	GPS
12	SYNCHRONIZATION	Case: GPS option. For each S/S, specify the length of the cable from the TDU-100E module to the antenna (the standard cable length is 30 m)	S/S A: 30 m S/S B: 40 m
13	LOGIC INPUTS	Select the type of input module: standard (5 inputs, dry); option 1 (5 inputs, wet); option 2 (8 inputs, 125 V DC); option 3 (8 inputs, 250 V DC).	Option 1
14	LOGIC INPUTS	Select the number of modules: 1 or 2	1

15	LOGIC OUTPUTS	Select the optional DO module if you want more than two alarms	NO
16	COMMUNICATION	For each S/S, specify if TDU's are concentrated or distributed in kiosks	S/S A and B: concentrated
17	COMMUNICATION	Case: kiosks. For each S/S, specify the distance between TDU's.	--
18	COMMUNICATION	For each S/S, specify the type of communication inside the plant (dial up, point to point, TCP/IP), and between kiosks (if applicable).	S/S A, B: TCP/IP
19	COMMUNICATION	Specify the connection of the Master Unit to the TDU-100E modules (dial up, point to point, TCP/IP).	S/S A, B: TCP/IP
20	COMMUNICATION	Specify if you want the IEC61850-8 type of communication.	NO

From the above, the offer could be the following.

- Number of TDU-100E units: 2.
- For each TDU-100E unit:
 - Two AI modules.
 - 6 split-core transformers for 5 A (type 1250T) with 5m cable.
 - GPS module.
 - I/O module: 5 inputs, option 1 (with voltage).
 - I/O module: one.
 - DO module: no.
 - COMM module: standard.
 - Power supply module: Basic module: 85 to 264 V, 50/60 Hz AC or 90 to 260 V DC.

APPENDIX 1: SUMMARY OF AVAILABLE MODULES

The following is the list of all optional modules which are available for TDU-100E. Optional modules are to be specified at order.



15	14	13	12	11	10	9	8	7	6	5	4	3	2	1
Power supply	COM	SYN	D I	D I			A N	A N	A N	A N	A N	A N	A N	A N

15: Power supply

- A) 85 V to 264 V AC, or 90 V to 260 V DC + 2 alarms (**Base model**).
- B) 35 V to 140 V DC + 2 alarms.
- C) 100 V to 300 V DC + 2 alarms.

14: COMmunication module

- A) Internal MODEM + N. 1 RS232 + N. 2 ETHERNET (**Base model**).
- B) N. 2 RS232 + N. 2 ETHERNET.

PROTOCOLS:

- 1) ETHERNET / IEC61870-5-104
- 2) ETHERNET / IEC61850-8 (optional)
- 3) RS232 / IEC61870-5-103
- 4) RS232 / DNP 3.0 (**Base model**).

13: SYNChronization module

I: Internal GPS synchronizer, with 3 m coaxial cable, surge arrester, 30 m connection cable, antenna with support and fixtures (**Base model**).

Optional antenna cable length:

- A) 30 m (**Base model**).
- B) 40 m.
- C) 50 m.
- D) 60 m.
- E) 100 m.

Other synchronization modules:

- A) IRIG-B DC, 5 V, TTL level (BNC);
- B) 1PPS input, 5 V TTL level (BNC) + time message input from GPS clock: serial RS-485;
- C) Optical IRIG-B DC;
- D) Optical 1PPS input + optical time message input from GPS clock (ST).

12 & 11: Digital inputs

- S: 5 separate digital inputs, dry contact (**Base model**).
- 1: 5 separate digital inputs, wet contact, 35 to 140 V DC.
- 2: 8 digital inputs, wet contact, 125 V DC, with common reference.
- 3: 8 digital inputs, wet contact, 250 V DC, with common reference.

10 & 9: Available.

- 0: Stand-by panel (**Base model**).

8 to 1: analog inputs

- 0: Stand-by panel (**Base model for 8 to 2**).
- A: Analog input type AD.
- B: Analog input type AI, with split core 1 A CT (**Base model for 1**).
- C: Analog input type AI, with split core 5 A CT (**Alternative base model for 1**).

Basic model split core CT cable length: 5 m

Optional split core CT cable length:

- 1) 7 m
- 2) 10 m
- 3) 20 m

- D: Analog input type AI, with external CT and protective box.
- E: Analog input type AV.