

# GLOBAL MONITORING for HV Cables

---



**ALTANOVA**  
GROUP

Advanced testing and monitoring solutions

**TECHIMP**

**isa**

## OLCM - On Line Cable Monitoring

### One System for Permanent PD Monitoring

- Patented technology
- Partial Discharge detection
- Enhanced noise rejection through realtime pulse analysis based on patented T/F map
- Separation and classification of different PD phenomena
- Time trend of elaborated quantities extracted from the PDA relevant to each single PD phenomenon, such as Qmax, repetition rate and many others
- Distance to fault location

### Preventing Failure on HV Cables with OLCM

The OLCM system, by continuously measuring and trending Partial Discharge activity, helps our customers to prevent major faults in HV cables.

Main defects in HV cables are:

- Internal PD in the cable and its accessories
- Surface PD on cable terminations
- Corroded shield
- Broken Jacket

### Typical reasons for harmful PD

Different aging processes are at the same time present on the same cable circuit:

#### ELECTROTHERMAL AGEING

- Breaking of polymeric chains
- Insulating material oxidation

#### THERMAL CYCLING

- Thermal cycles (expansion and contractions) due to different load conditions

#### MECHANICAL AGEING

- Vibration and mechanical forces due to both external causes and electromagnetic forces caused by flowing current

#### EXTERNAL ENVIRONMENT AGEING

- Possible ingress of moisture and/or external contaminants

### Main Functions of OLCM

#### Continuous PD Detection

OLCM continuously monitors the PD activity in HV cable using Altanova Techimp state of the art technology and patented T/F map noise rejection. The system is configurable in order to reject noise and to acquire only partial discharge signal for the alarm evaluation. It is also possible to discriminate different type of phenomena, and assign to them different alarm algorithms with different thresholds. Data can be visualized as PRPD standard pattern (with multiple selection for comparison) as well as T/F map. Statistical parameters such as Qmax, Nw (and more) are also provided for each acquisition.

Advanced PD processing and identification is possible through an additional software application.

### Benefits of TECHIMP T/F MAP® Technology

- Phenomena separation (Noise, Disturbances, Multiple PD activities, etc.)
- Noise rejection
- Single phenomenon identification
- PD Localization

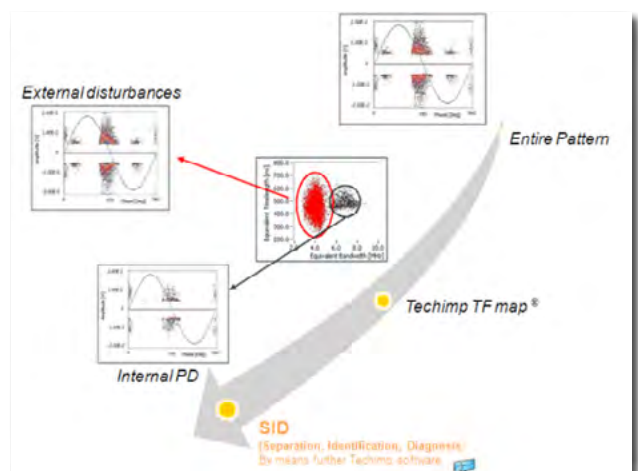

## OLCM System Description

OLCM permanently monitors the PD activity of HV cables. It is a modular system that includes:

- **PD Hub™** including the **PD Acquisition Unit**
- Different kinds of **sensors** according to the type of application (HFCT, Clamp HFCT, Flexible Magnetic Coupler, TEV sensor)
- A **Central Unit** with monitoring software TiSCADA that shows real time data, trends and current profiles and allows data analysis.

OLCM system has modular and flexible architecture that allows to design the global monitoring system according to our customer requirements.

## Components

### PD Hub™

The PD Hub™ is the core of the PD monitoring system and is available as a 3, 6, 9 and 12-channel device.

Its UWB acquisition unit operates from 16kHz to 30MHz with a fast sampling rate of 100MS/s and captures the entire waveform of a large number of pulses. The T/F map allows to differentiate between different pulses with different shapes (T/F map) hence improving the signal to noise ratio and collect mainly pulses related to PD activity.

The unit is powered and protected by a LV switchboard. The PD Hub™ is available in IP65 as well as IP68, where required. Usually the PD Hub™ is installed close to the cable terminations and cable joints.



PD Hub™

## OLCM Sensors

Several sensors are used to detect PD signals coming from inside the cable. The most often used type of sensor for cable PD monitoring is the HFCT. TECHIMP's family of HFCT combine an excellent frequency response with robustness a long-lasting installation. At cable terminations, sensors are usually installed inside grounding boxes or directly on the ground connection cables at GIS or transformer termination. At cable joints, HFCT are integrated in the link-box either around the ground connection cables or around cross-bonding bars inside.

TECHIMP offers a wide range of sensors:

- HFCT sensor Ø 30-50 mm
- HFCT clamp sensors Ø 39-140 mm
- FMC Flexible Magnetic Coupler
- TEV Sensor

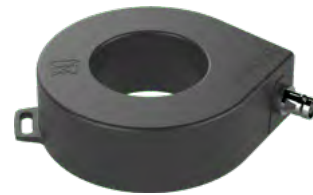

HFCT sensor Ø 30-50-87 mm

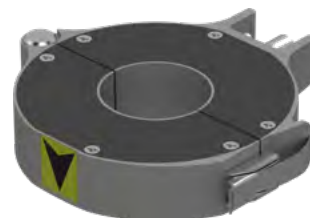

HFCT clamp sensor  
Ø 39-140 mm



FMC Flexible  
Magnetic Coupler



TEV sensor

## HFCT installations

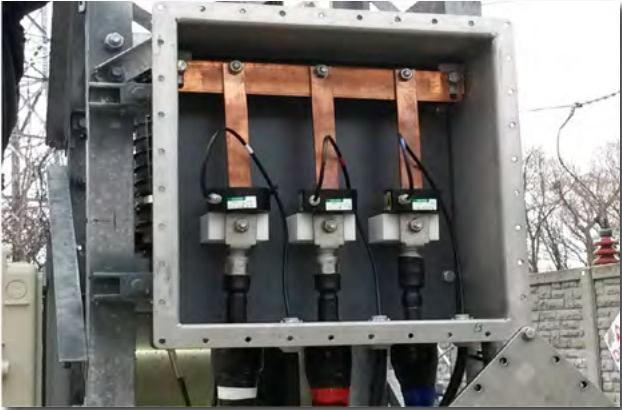

HFCT installation on OUTDOOR TERMINATIONS, inside grounding box.



HFCT installation on SECTIONALIZED CABLE JOINTS, around ground connection cables inside link-box.



HFCT installation on SECTIONALIZED CABLE JOINTS, around ground connection cables outside link-box.

## PPS Permanent Power Supply for PD HUB



PPS concept has been developed to allow permanent PD monitoring on HV cable joints when there is no LV power available at the manholes.

PPS gets the required energy from the High Voltage power line under monitoring by means of one or more toroidal units clamped on the HV power cable(s). PPS is able to continuously supply up to 60W @ 24Vdc when the HV cable is energized and allows to have a synchronization signal for the whole OLCM system. PPS is made up of two main devices: the clamp toroidal transformer (180mm diameter max) and the electronic controlled supply unit.

Depending on the power level required from the PD system, the PPS is able to provide up to 60W using up to three clamp transformers.

## Central Unit with Monitoring Software TiSCADA

The central unit is a 19" rack cabinet containing the server and the processing software. The server is an industrial PC with redundant hard drives and power supplies, to ensure maximum reliability. The software is supplied as virtualized system (Virtual Machine), so it can be easily restored and moved to other machines. The central unit contains also an industrial monitor and a keyboard/mouse.

It can be provided with an UPS and a WatchDog unit capable to notify system alarms.

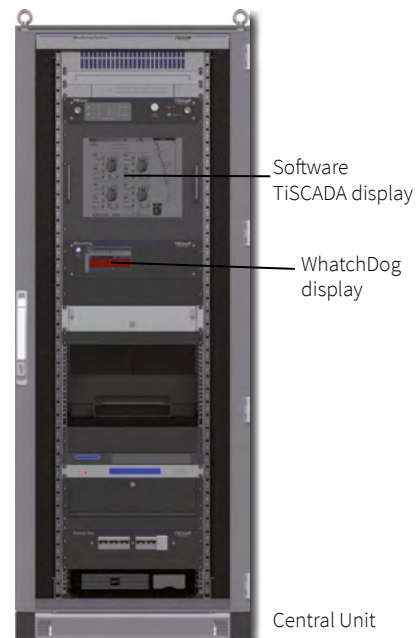

## Fiber Optic Communication and LV Power Supply

The PD Acquisition Unit installed inside each PD Hub™ shall be powered by means 5 Vdc, 2 A max. The PD Hub™ shall be powered by a low voltage power feeder through the protection switchboard installed inside. All PD Hub™ and the central unit are connected together by means of a fiber optic network

This network is made as a loop, in order to prevent a failure in the communication in case of interruption of one segment of fiber. The fiber can be either single-mode or multi-mode, terminated with ST connectors.

## OLCM System Architecture

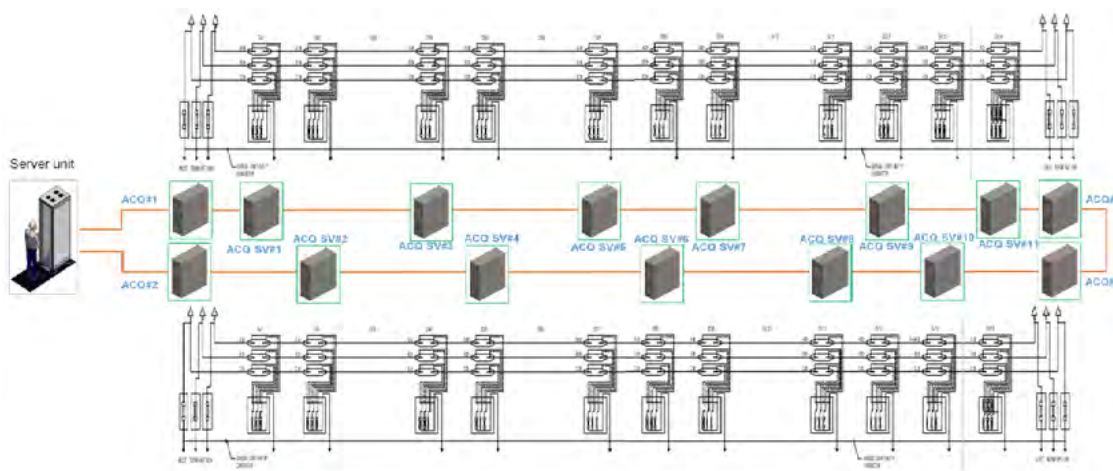

## TiSCADA

The graphical interface of the TECHIMP PD Monitoring System (TiSCADA) reports the status of the monitored electrical assets in a single synoptic screen (named “synoptic view”). This screen allows to spot any part of the insulation system affected by partial discharges. In addition it is possible to analyze acquired data, to plot data trending and to perform advanced queries to the Database (e.g. comparing data among equipments of the same plant, among the phases of the same EUT, the PD data can be correlated with the trend of other monitored quantities such as temperature, load, etc...). Thanks to the Web Server the graphical interface of the system can be accessed locally or by any other user connected (by means of LAN or modem) to the Central Control unit, with proper login credentials. Allowing maintenance personnel and asset management to access the PDM data with no need of dedicated software.



## Premium Services on HV Cable

With more than 4000 services and installations in any type of electrical asset and for any electrical apparatus Techimp has reached the excellence in converting research and innovation into practical, field-proven applications.

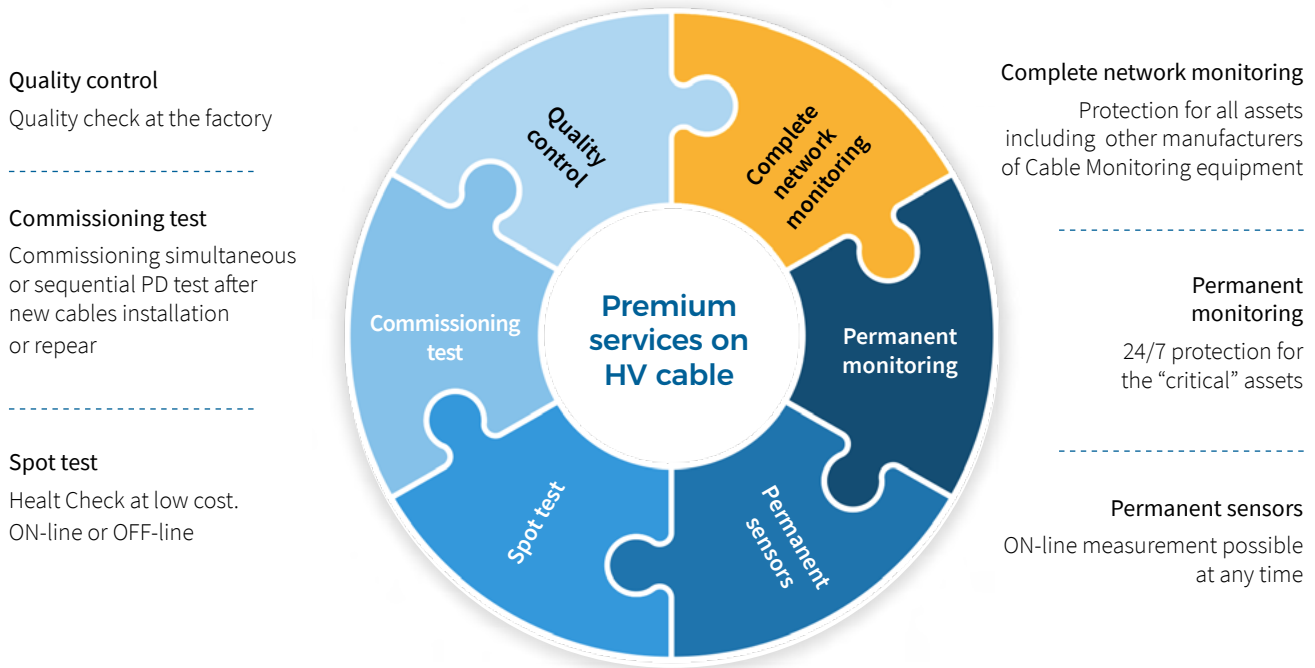

## Related Devices for PD Acquisition and Analysis

### PDBASE II® Laboratory and factory test analysis



**PDBase II®** has been expressly designed as a system able to collect a large number of PD pulses and separate them according to their waveform. It is common that PD activities overlap the noise at the same time. Even very skilled operators will find hard to make a diagnosis, in situations as the one mentioned above, through a mere visual evaluation of the pattern graph. Techimp new technology bases itself on the principle that efficient separation and identification of PD data can be achieved collecting PD pulses themselves and not only, as digital instrumentation commonly available does, PD pulse peak and phase. Innovative instrument for Partial Discharge recording & processing Ultra Wide band, fast integrated processing capability Up to 6 PD Channels, external, line or GPS synchronized Powerful, PD Pulse detector and Waveform analyzer Fuzzy logicdiagnostic tools and statistical processing IEC 60270 compliant.

### AQUILA all-in-one portable PD Acquisition Unit



**AQUILA** has been designed for being a robust and compact portable all-in-one PD detection station providing a full range of options ideal for on field applications. It can cope with the toughest outdoor conditions while taking measurements on any electrical asset. 15 years of service experience has been condensed in this unit integrating TECHIMP innovative PD detection technology with multiple connectivity (Wi-Fi, Fiber Optics, USB, Bluetooth) and power supply. The battery-powered unit allows testing activities for up to 20 hours without auxiliary power available. The setup of the unit is simple and fast allowing for taking measurements within minutes. The most outstanding feature is that it can be used for testing of MV and HV cables, power and distribution transformers, motors and generators, GIS and MV switchgears together with the right combination of sensors and filters. AQUILA can be used to measure on-line and off-line any electrical asset at any level of voltage and for any voltage waveform. It can be also used to install a permanent monitoring system, maintaining the needed degree of safety. The connection via fiber optic allows a network of acquisition units to be checked in different measurement points.

## System Specification

PD SCOPE					
PD Channels	3 based UWB Channels (expandable to 6 or 12)				
Bandwidth	16kH-30MHz, built in UWB filter (extendable to 1GHz with external Frequency Shifter, installed in the PDHub)				
Resolution	10 bit				
Input Impedance	50 Ohm				
Recording time length	1 $\mu$ s (min) 20 $\mu$ s (max)				
Connectors type	BNC				
Sampling rate	100 MS/s				
PD HUB					
Material	Steel, painted RAL 7035 (other colours and materials available)				
Communication	Ethernet RJ45 and/or fiber optic ST				
Protection degree	IP 65 - IP 68				
Dimensions	600x600x221mm (PDHub-3&6CH) ; 800x800x250mm (PDHub-12CH)				
Weight	Approx. 35kg (PDHub-3&6CH) ; Approx 50kg (PDHub-12CH)				
Power requirement	50W MAX for standard configuration ; 220VAC 50/60Hz (other on request)				
Working temperature range	Standard +5°C ÷ +50°C Extended with heating option: -20° ÷ +50°C Extended with cooling option: +5°C ÷ +65°C Extended with heating and cooling option: -20° ÷ +65°C				
HFCT PD sensor (Ø 30mm)		HFCT PD sensor (Ø 50mm)		HFCT PD sensor (Ø 87mm)	
Bandwidth (-6dB)	1MHz ÷ 60 MHz	Bandwidth (-6dB)	1MHz ÷ 80 MHz	Bandwidth (-6dB)	0.3MHz ÷ 15 MHz <sup>1</sup>
Max sensitivity (Vout / lin at 42 MHz, 50 $\Omega$ load)	17 mV / mA	Max sensitivity (Vout / lin at 42 MHz, 50 $\Omega$ load)	15 mV / mA	Max sensitivity (Vout / lin at 1 MHz, 50 $\Omega$ load)	10 mV / mA
Load impedance	50 $\Omega$	Load impedance	50 $\Omega$	Load impedance	50 $\Omega$
Hole dimension	Ø 30.5 mm	Hole dimension	Ø 50 mm	Hole dimension	Ø 87 mm
Operating temperature	-20°C ÷ +70°C	Operating temperature	-20°C ÷ +70°C	Operating temperature	-20°C ÷ +70°C
CLAMP HFCT PD sensor (Ø 39mm)		CLAMP HFCT PD sensor (Ø 140mm)			
Bandwidth (-6dB)	1MHz ÷ 80 MHz	Bandwidth (-6dB)	2MHz ÷ 100 MHz		
Max sensitivity (Vout / lin at 42 MHz, 50 $\Omega$ load)	15 mV / mA	Max sensitivity (Vout / lin at 42 MHz, 50 $\Omega$ load)	10 mV / mA		
Load impedance	50 $\Omega$	Load impedance	50 $\Omega$		
Hole dimension	Ø 39 mm	Hole dimension	Ø 140 mm		
Operating temperature	-20°C ÷ +70°C	Operating temperature	-20°C ÷ +70°C		
FLEXIBLE MAGNETIC COUPLER sensor		Permanent Power Supply (PPS)			
Bandwidth	500 kHz – 50 MHz	Max output power	60 W (using up to 3 toroids)		
Working principle	Inductive coupling	Output voltage	24 Vdc $\pm$ 5%		
Overall Dimensions (High Voltage version)	500 x 120 x 10 mm	Output current	Up to 2.5 A		
Connector	BNC	“Power Good” signal	Open collector, <24Vdc, <20mA		
Power Supply	Needed only for optional devices	Synchronization signal (V)	15 Vp/p, square wave		
Installation	Tied to the cable near cable joint or cable terminal	Sync phase shift respect primary current	6° $\pm$ 5°		
Operating temperature	-20°C ÷ +65°C	Supply current	0 ÷ 2kA (per phase)		

ALTANOVA is a leading company in the field of condition based monitoring and diagnostics of electrical apparatus. ALTANOVA has its roots in two strong and long experienced companies well set in the market of testing and monitoring: ISA and TECHIMP. The merger of the two companies provides synergies for the benefit of our customers in terms of giving access to new solutions and technologies.

ALTANOVA serves customers in more than 100 countries and operates with local offices in Germany, US, India, Singapore, Brazil and U.A.E.

We provide solutions covering a wide spectrum of industrial segments such as, transmission and distribution, oil & gas, process industries, EPCs, power generation, renewables, marine and transport and OEMs.

# ALTANOVA

GROUP

[www.altanova-group.com](http://www.altanova-group.com)

**TECHIMP**

**TECHIMP - ALTANOVA GROUP**

Via Toscana 11,

40069 Zola Predosa (Bo) - ITALY

**T** +39 051 199 86 050

**Email** [sales@altanova-group.com](mailto:sales@altanova-group.com)

**isa**

**ISA - ALTANOVA GROUP**

Via Prati Bassi 22,

21020 Taino (Va) - ITALY

**T** +39 0331 95 60 81

**Email** [sales@altanova-group.com](mailto:sales@altanova-group.com)